

# LEGEND

These standard symbols may be found in the drawing.

- ★ Light Pole
- CDNC. Concrete
- BIT. Bituminous
- ∅ Utility Pole
- WV Water Valve
- GV Gas Valve
- X - Chain Link Fence
- Boundary Line
- Edge of Road / Drive
- Stone Wall
- CB Catch Basin
- SMH Sewer Manhole
- I.P.S. 5/8" Iron Pin Set
- RR SPIKE FOUND Railroad Spike Found
- D.H.F. Drill Hole Found
- D.H.S. Drill Hole Set
- WLF 2 Wetland Flag
- GMS Granite Merestone
- EX. CDNC. MDN. Existing Concrete Monument
- T.B.S. To Be Set
- CHD CT Highway Department Monument
- Existing Contour Line
- BCLC Bit Conc. Lipped Curbing

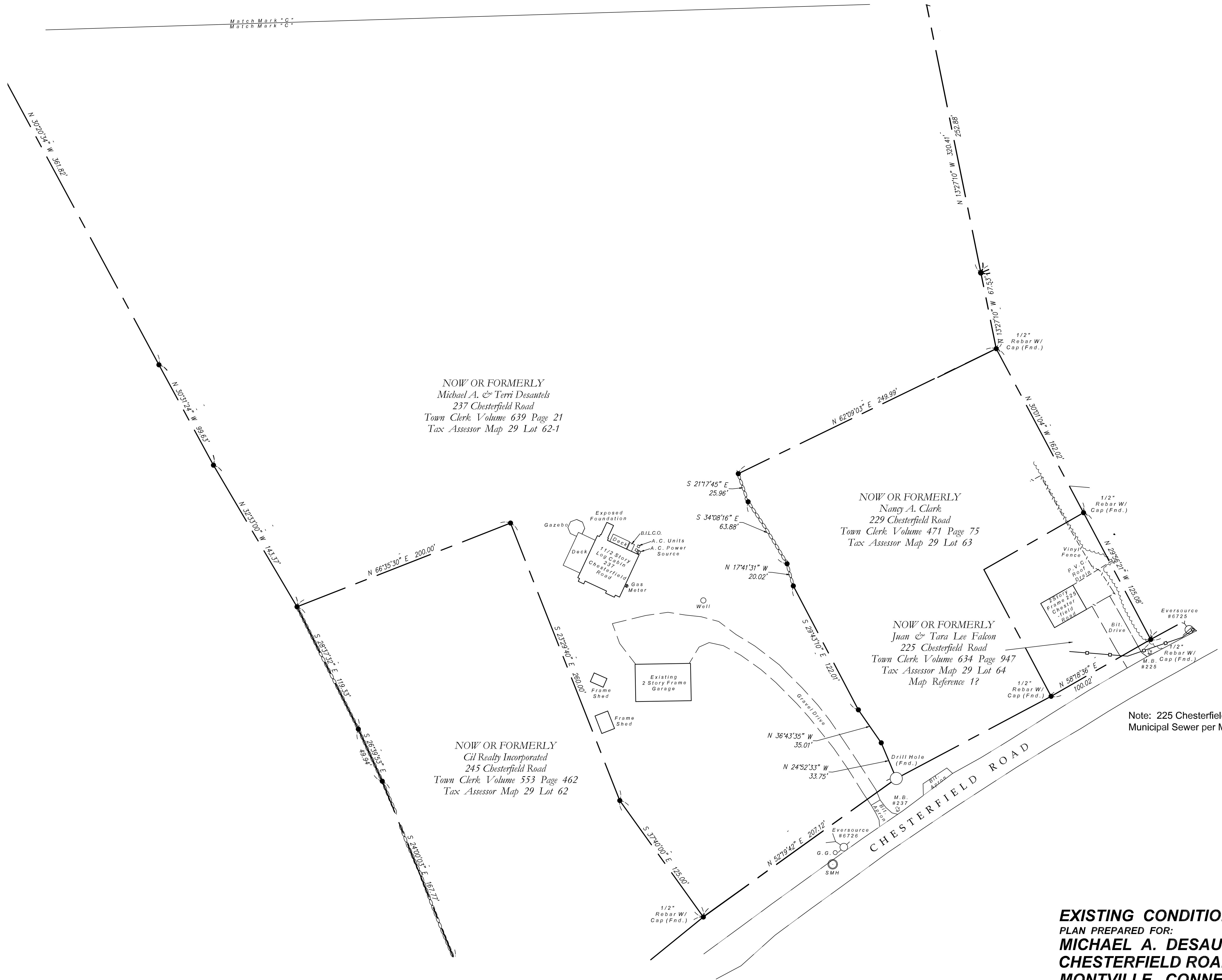

NOW OR FORMERLY  
Michael A. & Terri Desautels  
237 Chesterfield Road  
Town Clerk Volume 639 Page 21  
Tax Assessor Map 29 Lot 62-1

NOW OR FORMERLY  
Nancy A. Clark  
229 Chesterfield Road  
Town Clerk Volume 471 Page 75  
Tax Assessor Map 29 Lot 63

NOW OR FORMERLY  
Juan & Tara Lee Falcon  
225 Chesterfield Road  
Town Clerk Volume 634 Page 947  
Tax Assessor Map 29 Lot 64  
Map Reference 1?

NOW OR FORMERLY  
Gil Realty Incorporated  
245 Chesterfield Road  
Town Clerk Volume 553 Page 462  
Tax Assessor Map 29 Lot 62

Note: 225 Chesterfield Road is tied into Municipal Sewer per Montville WPCA.

**EXISTING CONDITIONS SURVEY**  
PLAN PREPARED FOR:  
**MICHAEL A. DESAUTELS**  
**CHESTERFIELD ROAD**  
**MONTVILLE, CONNECTICUT**  
SCALE: 1" = 40'  
JUNE 10, 2024  
REVISED THROUGH: AUGUST 24, 2025 Sheet 9 of 16

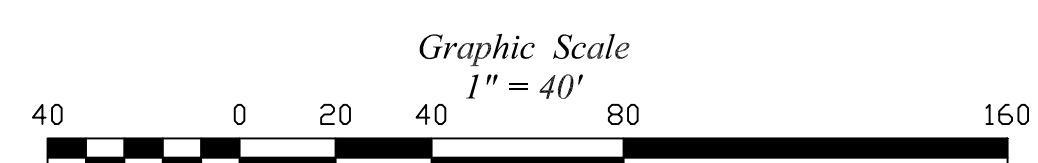

**LEGEND**

- These standard symbols may be found in the drawing.
- ★ Light Pole
  - CDNC. Concrete
  - BIT. Bituminous
  - U Utility Pole
  - WV Water Valve
  - GV Gas Valve
  - X - Chain Link Fence
  - Boundary Line
  - Edge of Road / Drive
  - Stone Wall
  - CB Catch Basin
  - SMH Sewer Manhole
  - I.P.S. 5/8" Iron Pin Set
  - RR SPIKE FOUND Railroad Spike Found
  - D.H.F. Drill Hole Found
  - D.H.S. Drill Hole Set
  - WLF 2 Wetland Flag
  - GMS Granite Merestone
  - EX. CDNC. MDN. Existing Concrete Monument
  - TBS To Be Set
  - CHD CT Highway Department Monument
  - Existing Contour Line
  - BCLC Bit Conc. Lipped Curbing

NOW OR FORMERLY  
Tadeusz J. & Charlene F. Kopy  
11 Caribou Way  
Town Clerk Volume 152 Page 320  
Tax Assessor Map 29 Lot 110

NOW OR FORMERLY  
Dwight W. Jones Jr. & Erica Swan  
46 Ortega Drive  
Town Clerk Volume 643 Page 314  
Tax Assessor Map 29 Lot 112

NOW OR FORMERLY  
Cynthia E. Santacrose  
45 Ortega Drive  
Town Clerk Volume 520 Page 216  
Tax Assessor Map 29 Lot 113

NOW OR FORMERLY  
Connecticut Light & Power Company  
Black Ash Road  
Town Clerk Volume 149 Page 108  
Tax Assessor Map 29 Lot 67

Note: Cross Hatched Area = Flood Zone "Other" as shown on FIRM Map, New London County, Connecticut, All Jurisdictions, Panel 333 of 554, Community: Town Of Montville, Map Number 09011C0333G, Effective Date: July 18, 2011.

NOW OR FORMERLY  
Michael A. & Terri Desautels  
237 Chesterfield Road  
Town Clerk Volume 639 Page 21  
Tax Assessor Map 29 Lot 62-001

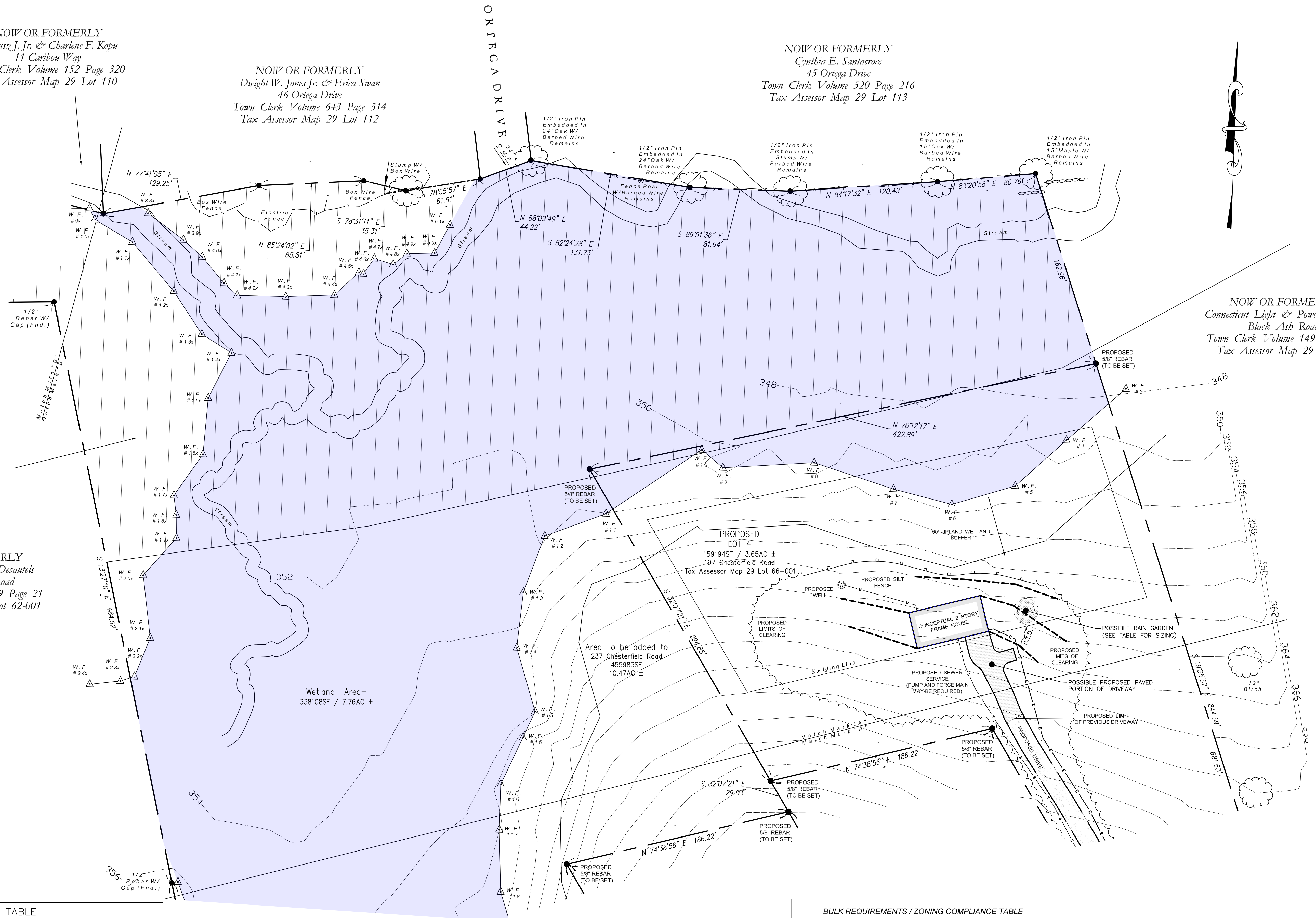

**RAIN GARDEN DATA TABLE**

LOT	PROPOSED IMPERVIOUS AREA	MINIMUM VOLUME	PROPOSED RAIN GARDEN CAPACITY
1	1,800 S.F. (POSS. HOUSE) 1,300 S.F. (PAVED DRIVE) 3,100 S.F. (APPROX. TOTAL)	±336 C.F.	TOP OF CONTOUR AREA = ±314 S.F. BOTTOM CONTOUR AREA = ±63 S.F. DEPTH = 2FT. PROPOSED VOLUME = ±377 C.F.
2	1,800 S.F. (POSS. HOUSE) 1,300 S.F. (PAVED DRIVE) 3,100 S.F. (APPROX. TOTAL)	±336 C.F.	TOP OF CONTOUR AREA = ±314 S.F. BOTTOM CONTOUR AREA = ±63 S.F. DEPTH = 2FT. PROPOSED VOLUME = ±377 C.F.
3	1,800 S.F. (POSS. HOUSE) 2,100 S.F. (PAVED DRIVE) 3,900 S.F. (APPROX. TOTAL)	±423 C.F.	TOP OF CONTOUR AREA = ±314 S.F. BOTTOM CONTOUR AREA = ±113 S.F. DEPTH = 2FT. PROPOSED VOLUME = ±427 C.F.
4	1,800 S.F. (POSS. HOUSE) 1,450 S.F. (PAVED DRIVE) 3,250 S.F. (APPROX. TOTAL)	±353 C.F.	TOP OF CONTOUR AREA = ±314 S.F. BOTTOM CONTOUR AREA = ±63 S.F. DEPTH = 2FT. PROPOSED VOLUME = ±377 C.F.

RAIN GARDENS SHALL BE SIZED FOR 108 C.F. OF VOLUME PER 1,000 S.F. MIN. OF PROPOSED IMPERVIOUS AREA TO ACCOMMODATE 1.3"(MIN.) RUNOFF FROM IMPERVIOUS SURFACES.

**BULK REQUIREMENTS / ZONING COMPLIANCE TABLE**  
R-80 ZONE FLAG LOT

	REQUIRED R-80	PROVIDED LOT 4
TOTAL LOT AREA:	120,000 SF	159,194 SF
MINIMUM LOT FRONTAGE:	25 FT	76.31 FT
MINIMUM FRONT YARD SETBACK:	75 FT	78 FT
MINIMUM SIDE YARD SETBACK:	20 FT	148 FT
MINIMUM REAR YARD SETBACK:	50 FT	168 FT
MAXIMUM BUILDING HEIGHT:	35 FT	<35 FT

Graphic Scale  
1" = 40'

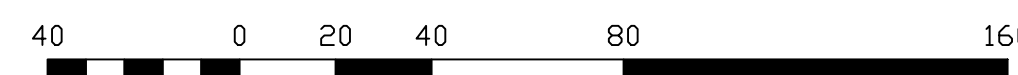

**RESUBIVISION SURVEY**  
CONCEPTUAL PLAN  
PREPARED FOR:  
**MICHAEL A. DESAUTELS**  
**CHESTERFIELD ROAD**  
**MONTVILLE, CONNECTICUT**  
SCALE: 1" = 40'  
JUNE 10, 2024  
REVISED: AUGUST 24, 2025

**LEGEND**

- These standard symbols may be found in the drawing.
- ★ Light Pole
  - CDNC. Concrete
  - BIT. Bituminous
  - U Utility Pole
  - WV Water Valve
  - GV Gas Valve
  - X - Chain Link Fence
  - Boundary Line
  - Edge of Road / Drive
  - Stone Wall
  - CB Catch Basin
  - SMH Sewer Manhole
  - IP.S. 5/8" Iron Pin Set
  - RR SPIKE FOUND Railroad Spike Found
  - D.H.F. Drill Hole Found
  - D.H.S. Drill Hole Set
  - WLF 2 Wetland Flag
  - GMS Granite Merestone
  - EX. CDNC. MDN. Existing Concrete Monument
  - TBS To Be Set
  - CT Highway Department Monument
  - Existing Contour Line
  - BCLC Bit Conc. Lipped Curbing

NOW OR FORMERLY  
Michael A. & Terri Desautels  
237 Chesterfield Road  
Town Clerk Volume 639 Page 21  
Tax Assessor Map 29 Lot 623001

**BULK REQUIREMENTS / ZONING COMPLIANCE TABLE  
R-80 ZONE LOT 1**

	REQUIRED R-80	PROPOSED LOT 1
TOTAL LOT AREA:	80,000 sf	80,079 sf
MINIMUM LOT FRONTAGE:	180 FT	200 FT
MINIMUM FRONT YARD SETBACK:	50 FT	53 FT
MINIMUM SIDE YARD SETBACK:	20 FT	60.8 FT
MINIMUM REAR YARD SETBACK:	50 FT	241 FT
MAXIMUM BUILDING HEIGHT:	35 FT	<35 FT

NOW OR FORMERLY  
Nancy A. Clark  
229 Chesterfield Road  
Town Clerk Volume 471 Page 75  
Tax Assessor Map 29 Lot 63

NOW OR FORMERLY  
Juan & Tara Lee Falcon  
225 Chesterfield Road  
Town Clerk Volume 634 Page 947  
Tax Assessor Map 29 Lot 64  
Map Reference 1?

Note: 225 Chesterfield Road is tied into Municipal Sewer per Montville WPCA.

**Drainage Easement:**

LINE	BEARING	DISTANCE
E-1	N 28°47'48" E	111.18'
E-2	S 61°12'12" E	20.00'
E-3	S 28°47'48" W	77.39'
E-4	S 59°25'00" W	39.27'

**BULK REQUIREMENTS / ZONING COMPLIANCE TABLE  
R-80 ZONE LOT 2**

	REQUIRED R-80	PROPOSED LOT 2
TOTAL LOT AREA:	80,000 sf	80,275 sf
MINIMUM LOT FRONTAGE:	180 FT	180 FT
MINIMUM FRONT YARD SETBACK:	50 FT	75 FT
MINIMUM SIDE YARD SETBACK:	20 FT	53 FT
MINIMUM REAR YARD SETBACK:	50 FT	330 FT
MAXIMUM BUILDING HEIGHT:	35 FT	<35 FT

**BULK REQUIREMENTS / ZONING COMPLIANCE TABLE  
R-80 ZONE LOT 3**

	REQUIRED R-80	PROPOSED LOT 3
TOTAL LOT AREA:	80,000 sf	80,275 sf
MINIMUM LOT FRONTAGE:	180 FT	180.52 FT
MINIMUM FRONT YARD SETBACK:	50 FT	77 FT
MINIMUM SIDE YARD SETBACK:	20 FT	53 FT
MINIMUM REAR YARD SETBACK:	50 FT	332 FT
MAXIMUM BUILDING HEIGHT:	35 FT	<35 FT

Note: 213 Chesterfield Road is tied into Municipal Sewer per Montville WPCA.

**BULK REQUIREMENTS / ZONING COMPLIANCE TABLE  
R-80 ZONE FLAG LOT**

	REQUIRED R-80	PROVIDED LOT 4
TOTAL LOT AREA:	120,000 sf	159,194 sf
MINIMUM LOT FRONTAGE:	25 FT	76.31 FT
MINIMUM FRONT YARD SETBACK:	75 FT	78 FT
MINIMUM SIDE YARD SETBACK:	20 FT	148 FT
MINIMUM REAR YARD SETBACK:	50 FT	168 FT
MAXIMUM BUILDING HEIGHT:	35 FT	<35 FT

**RAIN GARDEN DATA TABLE**

LOT	PROPOSED IMPERVIOUS AREA	MINIMUM VOLUME	PROPOSED RAIN GARDEN CAPACITY
1	1,800 S.F. (POSS. HOUSE) 1,300 S.F. (PAVED DRIVE) 3,100 S.F. (APPROX. TOTAL)	±336 C.F.	TOP OF CONTOUR AREA = ±314 S.F. BOTTOM CONTOUR AREA = ±63 S.F. DEPTH = 2FT. PROPOSED VOLUME = ±377 C.F.
2	1,800 S.F. (POSS. HOUSE) 1,300 S.F. (PAVED DRIVE) 3,100 S.F. (APPROX. TOTAL)	±336 C.F.	TOP OF CONTOUR AREA = ±314 S.F. BOTTOM CONTOUR AREA = ±63 S.F. DEPTH = 2FT. PROPOSED VOLUME = ±377 C.F.
3	1,800 S.F. (POSS. HOUSE) 2,100 S.F. (PAVED DRIVE) 3,900 S.F. (APPROX. TOTAL)	±423 C.F.	TOP OF CONTOUR AREA = ±314 S.F. BOTTOM CONTOUR AREA = ±113 S.F. DEPTH = 2FT. PROPOSED VOLUME = ±427 C.F.
4	1,800 S.F. (POSS. HOUSE) 1,450 S.F. (PAVED DRIVE) 3,250 S.F. (APPROX. TOTAL)	±353 C.F.	TOP OF CONTOUR AREA = ±314 S.F. BOTTOM CONTOUR AREA = ±63 S.F. DEPTH = 2FT. PROPOSED VOLUME = ±377 C.F.

RAIN GARDENS SHALL BE SIZED FOR 108 C.F. OF VOLUME PER 1,000 S.F. MIN. OF PROPOSED IMPERVIOUS AREA TO ACCOMMODATE 1.3"(MIN.) RUNOFF FROM IMPERVIOUS SURFACES.

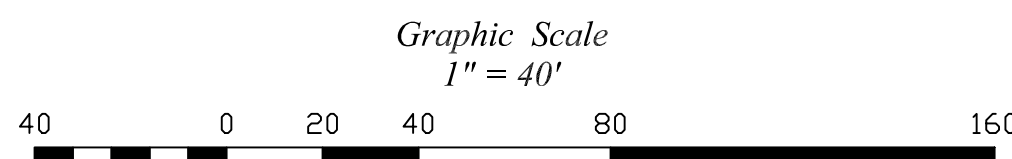
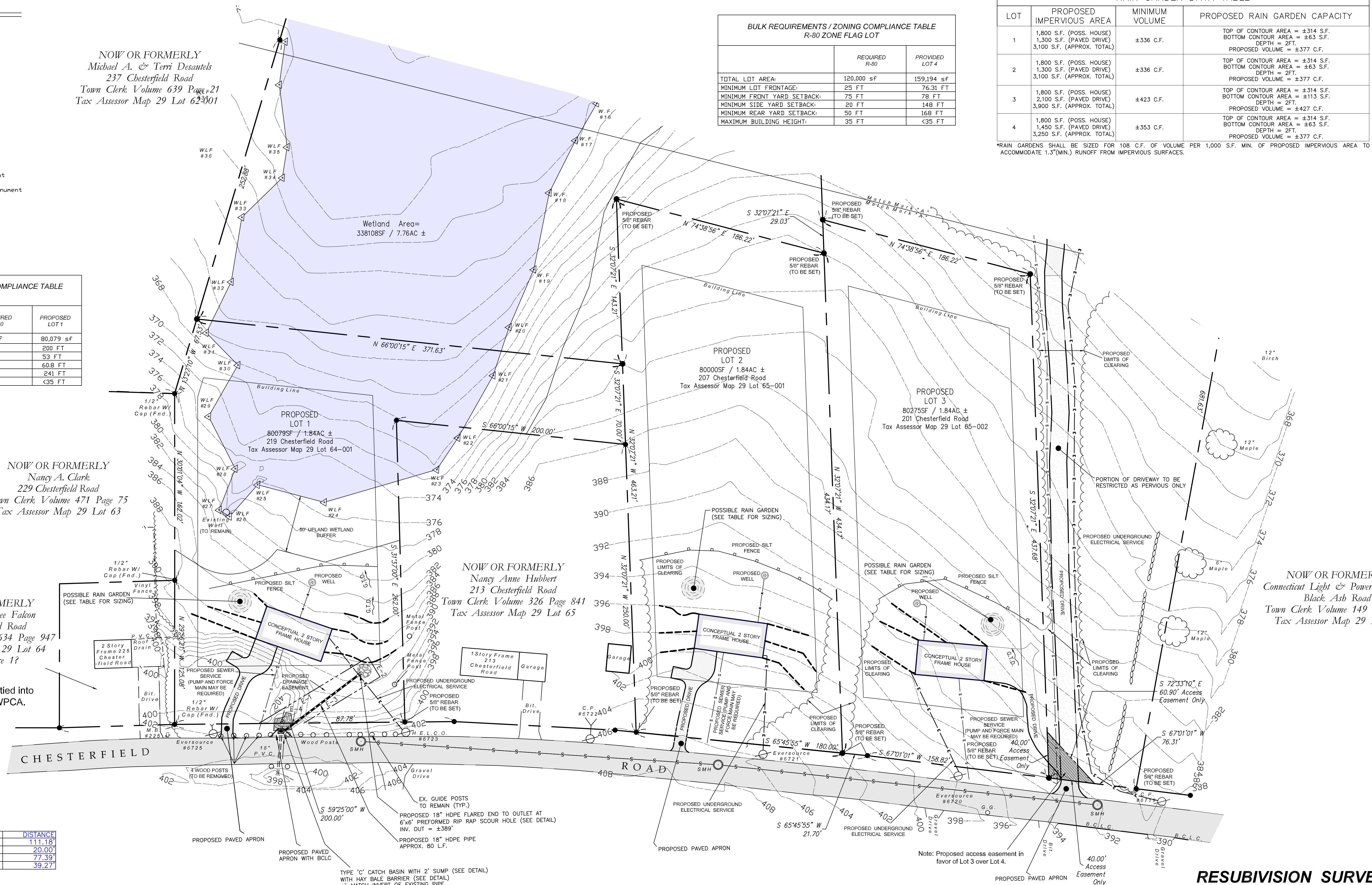

**RESUBIVISION SURVEY**  
CONCEPTUAL PLAN  
PREPARED FOR:  
**MICHAEL A. DESAUTELS**  
**CHESTERFIELD ROAD**  
**MONTVILLE, CONNECTICUT**  
SCALE: 1" = 40'  
JUNE 10, 2024  
REVISED: AUGUST 24, 2025

**LEGEND**

- These standard symbols may be found in the drawing.
- ★ Light Pole
  - CDNC. Concrete
  - BIT. Bituminous
  - ∅ Utility Pole
  - WV Water Valve
  - GV Gas Valve
  - X - Chain Link Fence
  - Boundary Line
  - Edge of Road / Drive
  - Stone Wall
  - Catch Basin
  - SMH Sewer Manhole
  - I.P.S. 5/8" Iron Pin Set
  - RR SPIKE FOUND Railroad Spike Found
  - D.H.F. Drill Hole Found
  - D.H.S. Drill Hole Set
  - WLF 2 Wetland Flag
  - GMS Granite Merestone
  - EX. CDNC. MDN. Existing Concrete Monument
  - T.B.S. To Be Set
  - CT Highway Department Monument
  - Existing Contour Line
  - BCLC Bit Conc. Lipped Curbing

NOW OR FORMERLY  
Jonathon A. Swift  
17 Caribou Way  
Town Clerk Volume 649 Page 1010  
Tax Assessor Map 29 Lot 109

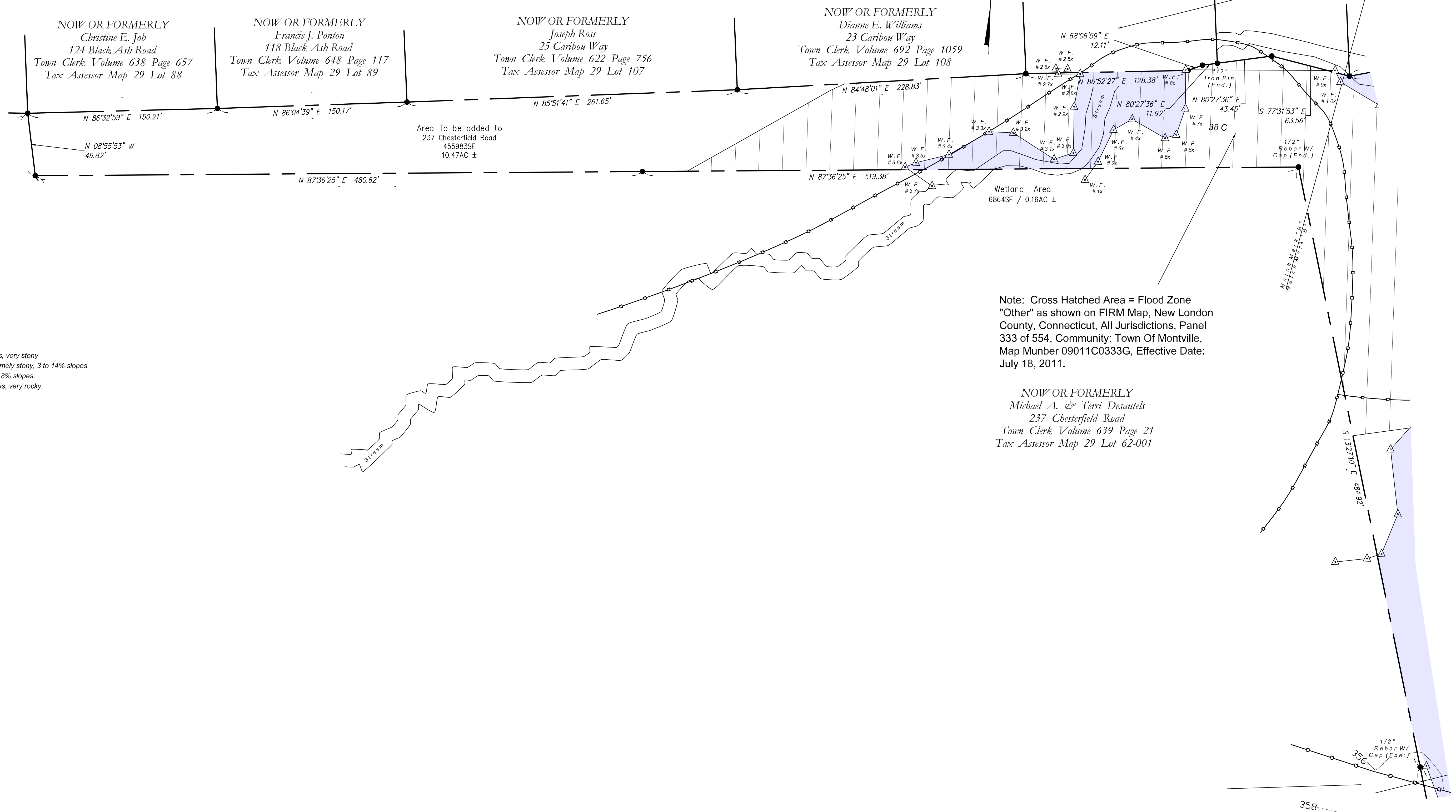

Area To be added to  
237 Chesterfield Road  
455983SF  
10.47AC ±

Note: Cross Hatched Area = Flood Zone  
"Other" as shown on FIRM Map, New London  
County, Connecticut, All Jurisdictions, Panel  
333 of 554, Community: Town Of Montville,  
Map Munber 09011C0333G, Effective Date:  
July 18, 2011.

NOW OR FORMERLY  
Michael A. & Terri Desautels  
237 Chesterfield Road  
Town Clerk Volume 639 Page 21  
Tax Assessor Map 29 Lot 62-001

- NOTES:**
- 1) Soil Classifications:
    - a. 46C Woodbury, fine sandy loam, 8 to 15% slopes, very stony
    - b. 3 Ridgebury, Leicester, and Whitman soils, extremely stony, 3 to 14% slopes
    - c. 84B Paxton and Montauk, fine sandy loams, 3 to 8% slopes.
    - d. 73E Charlton-Chatfield complex, 15 to 45% slopes, very rocky.

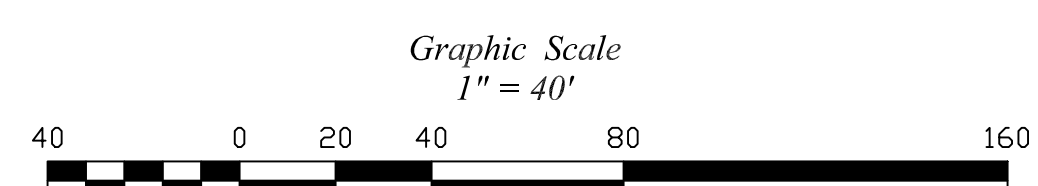

**RESUBDIVISION SURVEY**  
CONCEPTUAL PLAN  
PREPARED FOR:  
**MICHAEL A. DESAUTELS**  
**CHESTERFIELD ROAD**  
**MONTVILLE, CONNECTICUT**  
SCALE: 1" = 40'  
JUNE 10, 2024  
REVISED: AUGUST 24, 2025

# LEGEND

These standard symbols may be found in the drawing.

- ★ Light Pole
- CDNC. Concrete
- BIT. Bituminous
- ∅ Utility Pole
- WV Water Valve
- GV Gas Valve
- X - Chain Link Fence
- Boundary Line
- Edge of Road / Drive
- Stone Wall
- CB Catch Basin
- SMH Sewer Manhole
- I.P.S. 5/8" Iron Pin Set
- RR SPIKE FOUND Railroad Spike Found
- D.H.F. Drill Hole Found
- D.H.S. Drill Hole Set
- WLF 2 Wetland Flag
- GMS Granite Merestone
- EX. CDNC. MDN. Existing Concrete Monument
- TBS To Be Set
- CHD CT Highway Department Monument
- - - Existing Contour Line
- BCLC Bit Conc Lipped Curbing

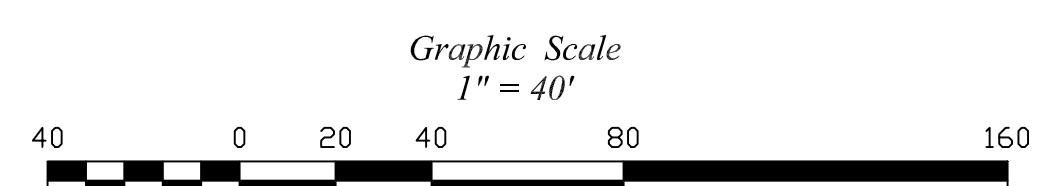

**RESUBIVISION SURVEY**  
 SIGHT LINE SURVEY  
 PREPARED FOR:  
**MICHAEL A. DESAUTELS**  
**CHESTERFIELD ROAD**  
**MONTVILLE, CONNECTICUT**  
 SCALE: 1" = 40'  
 JUNE 10, 2024  
 REVISED: AUGUST 24, 2025

# LEGEND

These standard symbols may be found in the drawing.

- ★ Light Pole
- CDNC. Concrete
- BIT. Bituminous
- ∅ Utility Pole
- WV Water Valve
- GV Gas Valve
- X - Chain Link Fence
- - - Boundary Line
- Edge of Road / Drive
- Stone Wall
- CB Catch Basin
- SMH Sewer Manhole
- I.P.S. 5/8" Iron Pin Set
- RR SPIKE FOUND Railroad Spike Found
- D.H.F. Drill Hole Found
- D.H.S. Drill Hole Set
- WLF 2 Wetland Flag
- GMS Granite Merestone
- EX. CDNC. MDN. Existing Concrete Monument
- T.B.S. To Be Set
- CHD CT Highway Department Monument
- - - Existing Contour Line
- BCLC Bit Conc. Lipped Curbing

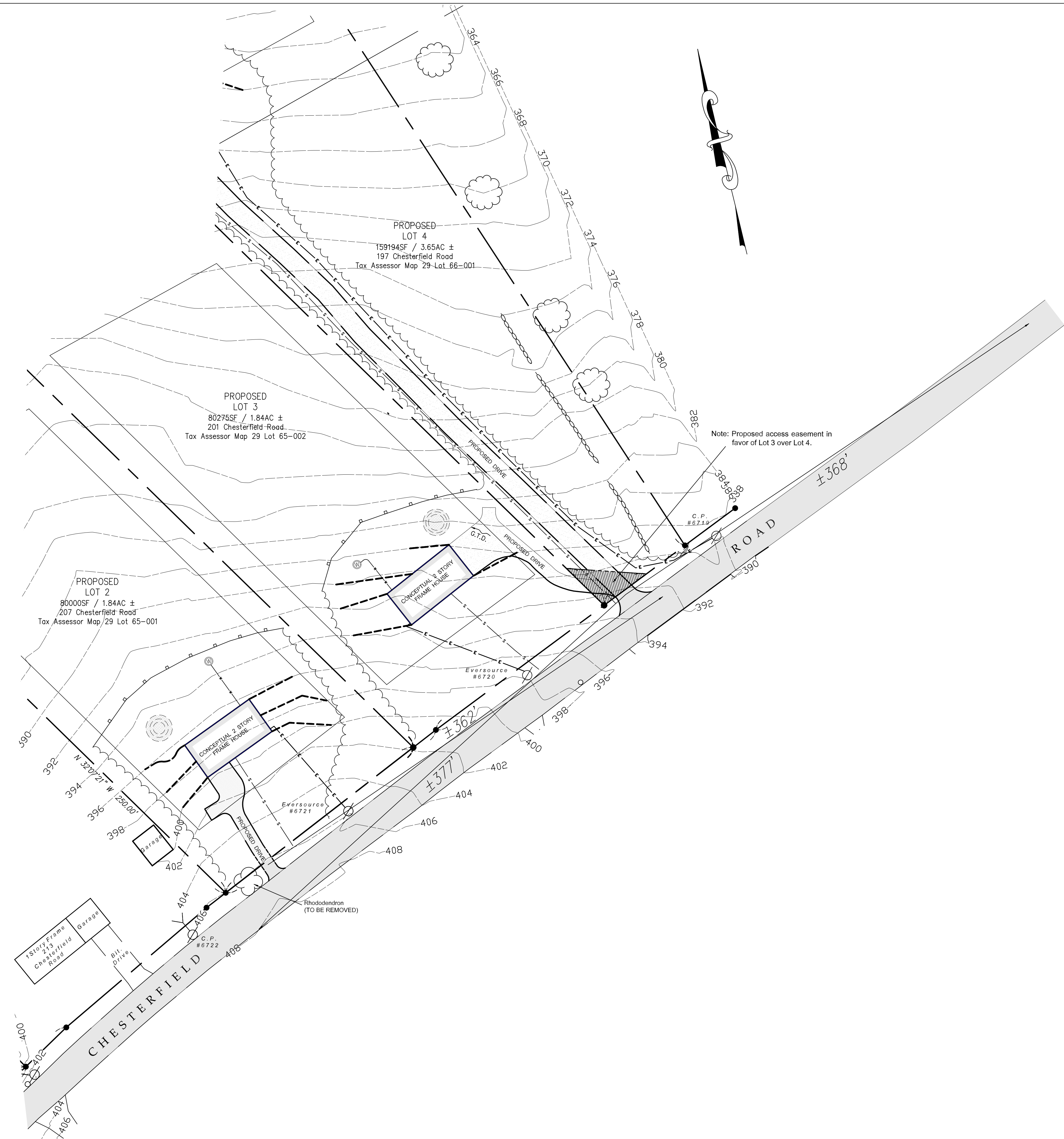

**RESUBIVISION SURVEY**  
 SIGHT LINE SURVEY  
 PREPARED FOR:  
**MICHAEL A. DESAUTELS**  
**CHESTERFIELD ROAD**  
**MONTVILLE, CONNECTICUT**  
 SCALE: 1" = 40'  
 JUNE 10, 2024  
 REVISED: AUGUST 24, 2025

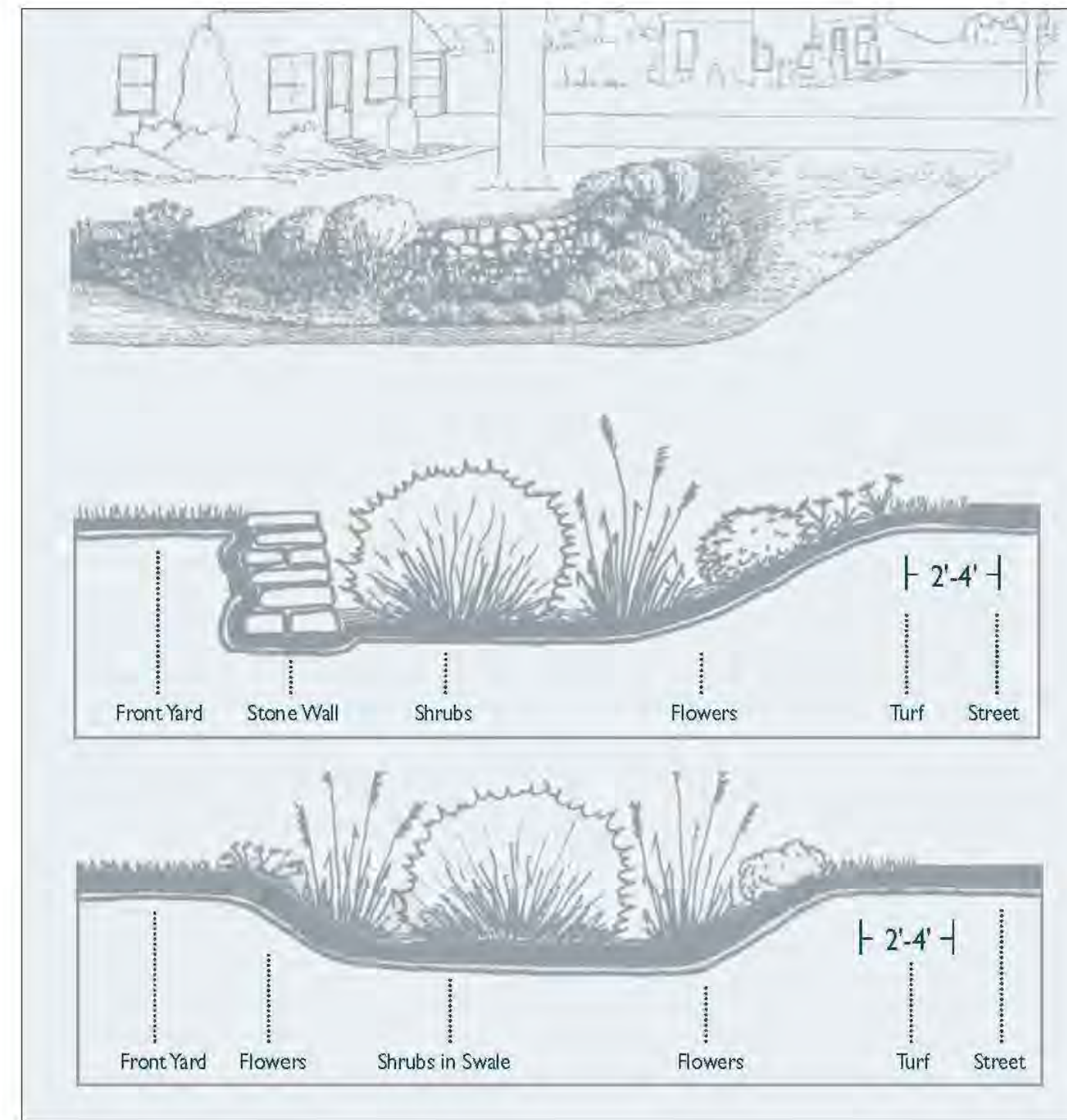

**CONNECTICUT DEEP STORMWATER QUALITY MANUAL –  
TYPICAL RAIN GARDEN DETAIL**  
NOT TO SCALE

**ERNST SEED MIXTURE SCHEDULE**

- RAIN GARDEN FLOOR MIX – SEED MIXTURE SPECIFICATION
- 25% REDTOP PANICGRASS, PA ECOTYPE (PANICUM RIGIDULUM (P. STIPITATUM), PA ECOTYPE)
  - 16% VIRGINIA WILDRYE, PA ECOTYPE (ELYMUS VIRGINICUS, PA ECOTYPE)
  - 16% ALKALIGRASS, "FULTS" (PUCCINELLIA DISTANS, "FULTS")
  - 15% FOWL BLUEGRASS (POA PALUSTRIS)
  - 10% CREEPING BENTGRASS (AGROSTIS STOLONIFERA)
  - 10% TICKLEGRASS (ROUGH BENTGRASS), PA ECOTYPE (AGROSTIS SCABRA, PA ECOTYPE)
  - 5% SOFT RUSH (JUNCUS EFFUSUS)
  - 2% AUTUMN BENTGRASS, PA ECOTYPE (AGROSTIS PERENNANS, PA ECOTYPE)
  - 1% PATH RUSH, PA ECOTYPE (JUNCUS TENUIS, PA ECOTYPE)

**RAIN GARDEN CONSTRUCTION NOTES**

1. RAIN GARDEN SHALL NEVER BE USED FOR SEDIMENT CONTROL DURING AN ACTIVE CONSTRUCTION PERIOD.
2. THE AREA OF THE RAIN GARDEN SHALL BE MARKED OFF BY APPROPRIATE FENCING TO PREVENT THE MOVEMENT OF CONSTRUCTION VEHICLES OVER AND THE POSSIBLE COMPACTION OF THE NATURAL SOILS.
3. DURING CONSTRUCTION, SEDIMENT SHALL BE PREVENTED FROM ENTERING THE AREA OF THE RAIN GARDEN. THE CONTRACTOR SHALL INSURE THAT 100% GRASS COVER IS QUICKLY ESTABLISHED AND MAINTAINED OVER THE ENTIRE AREA DRAINING TO THE RAIN GARDEN.
4. THE DESIGN ENGINEER SHALL OVERSEE THE PREPARATION OF THE AREA AND THE CONSTRUCTION OF THE RAIN GARDEN AND SHALL PROVIDE CERTIFICATION THAT THE SYSTEM WAS INSTALLED IN ACCORDANCE WITH THE APPROVED PLANS.
5. ALL DISTURBED AREAS SHALL BE FINE GRADED WITH 3" TOPSOIL, RAKED, SEEDED AND MULCHED IN A TIMELY MANNER. 100% GRASS COVER SHALL BE QUICKLY ESTABLISHED AND MAINTAINED TO PREVENT ANY SILT ACCUMULATION ALONG THE BOTTOM OF THE RAIN GARDEN. IF NECESSARY, THE CONTRACTOR SHALL INSTALL AN 18" HIGH WOOD CHIP BERM AROUND THE ENTIRE RAIN GARDEN AREA TO INHIBIT SILTATION.

**RAIN GARDEN MAINTENANCE PLAN**

1. VEGETATION SHALL BE MOWED AS NECESSARY TO MAINTAIN 4" TO 6" HEIGHT. ANY WOODY VEGETATION SHALL BE REMOVED FROM THE RAIN GARDEN.
2. NO PESTICIDES OR FERTILIZERS SHALL BE USED IN ANY AREA DRAINING TO THE RAIN GARDEN.
3. IF THERE IS AN ACCUMULATION OF ORGANIC DEBRIS OR SEDIMENT ON THE SURFACE OF THE RAIN GARDEN OR IF PONDED WATER IS REGULARLY OBSERVED MORE THAN 48 HOURS AFTER A RAINFALL EVENT, THE TOP 6" SHALL BE REMOVED AND THE EXPOSED SOIL SURFACE ROTOTILLED TO A DEPTH OF 12". AFTER THIS WORK HAS BEEN DONE, THE BOTTOM OF THE RAIN GARDEN SHALL BE RESTORED TO ITS ORIGINAL CONDITION.
4. INSPECTIONS OF THE RAIN GARDEN SHALL BE MADE AFTER MAJOR STORM EVENTS.

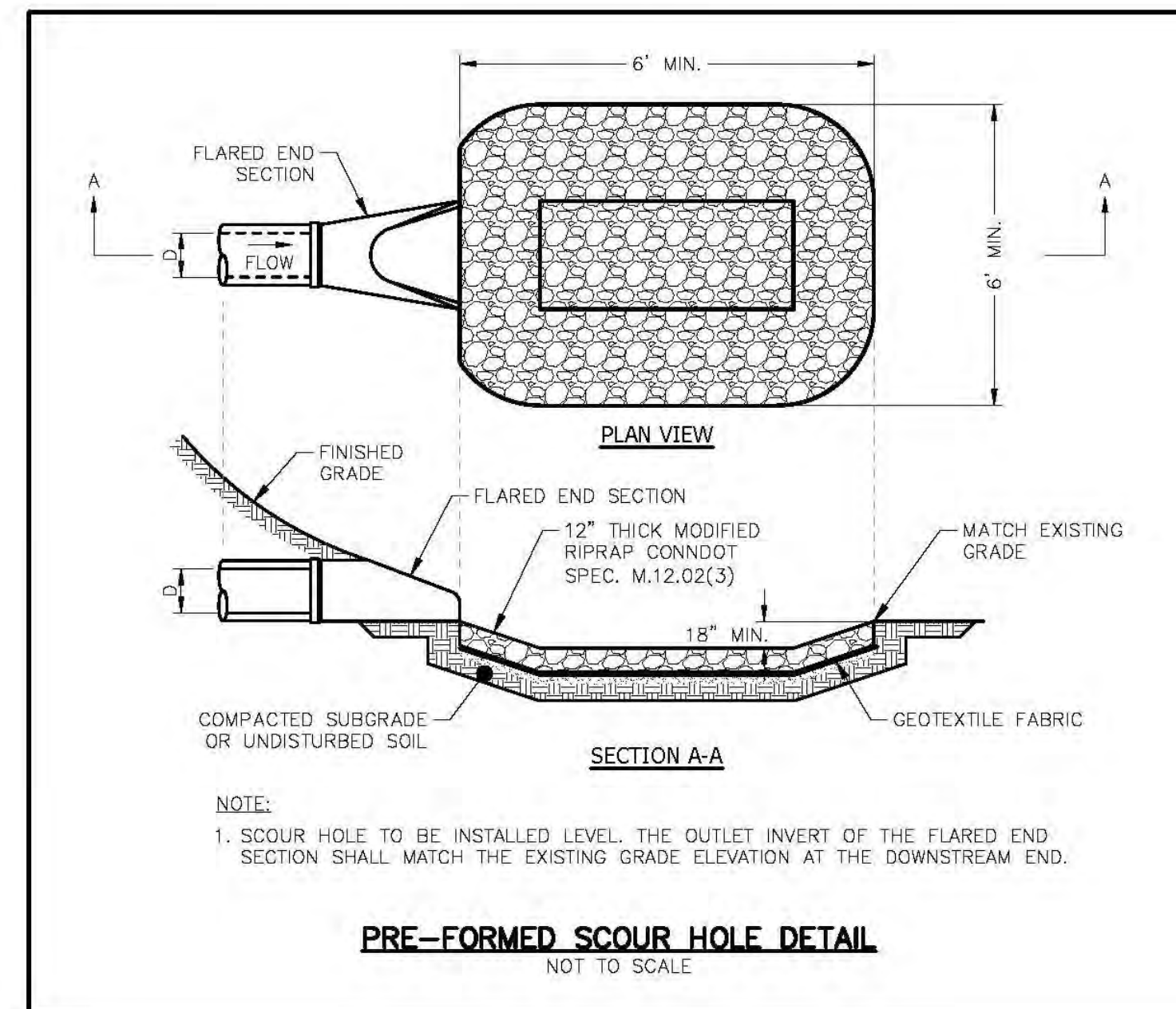

**PRE-FORMED SCOUR HOLE DETAIL**  
NOT TO SCALE

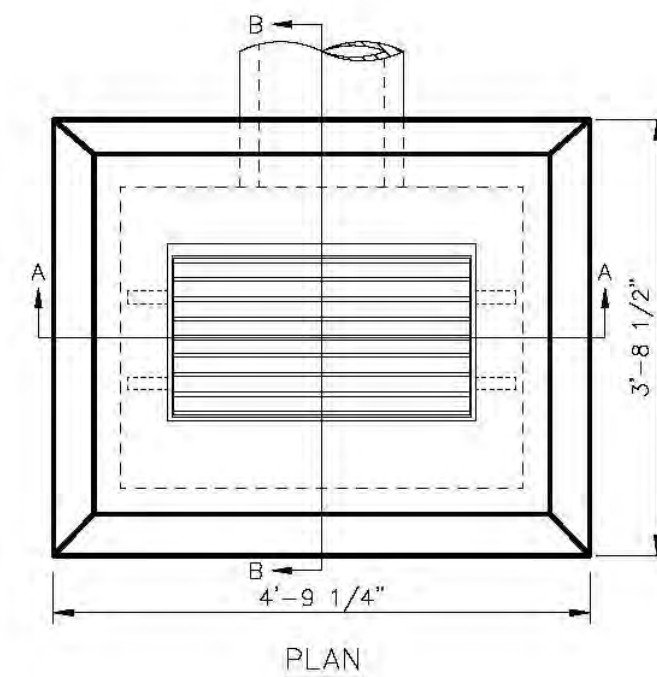

- NOTES:**
1. REMOVE HAYDALE OR FILTER FABRIC SILT BARRIER AFTER PERMANENT GROUND COVER HAS BEEN ESTABLISHED.
  2. CLEAN SUMPS AFTER REMOVAL OF BARRIER. CATCH BASINS SHALL BE PRECAST UNITS.
  3. ALL CATCH BASINS SHALL HAVE 2' SUMPS UNLESS OTHERWISE SPECIFIED.
  4. ALL GRATES SHALL BE CONDOT TYPE 'A'.
  5. ALL VOIDS AROUND PIPES ENTERING ALL EXISTING AND PROPOSED CATCH BASINS SHALL BE FIRMLY MORTARED.

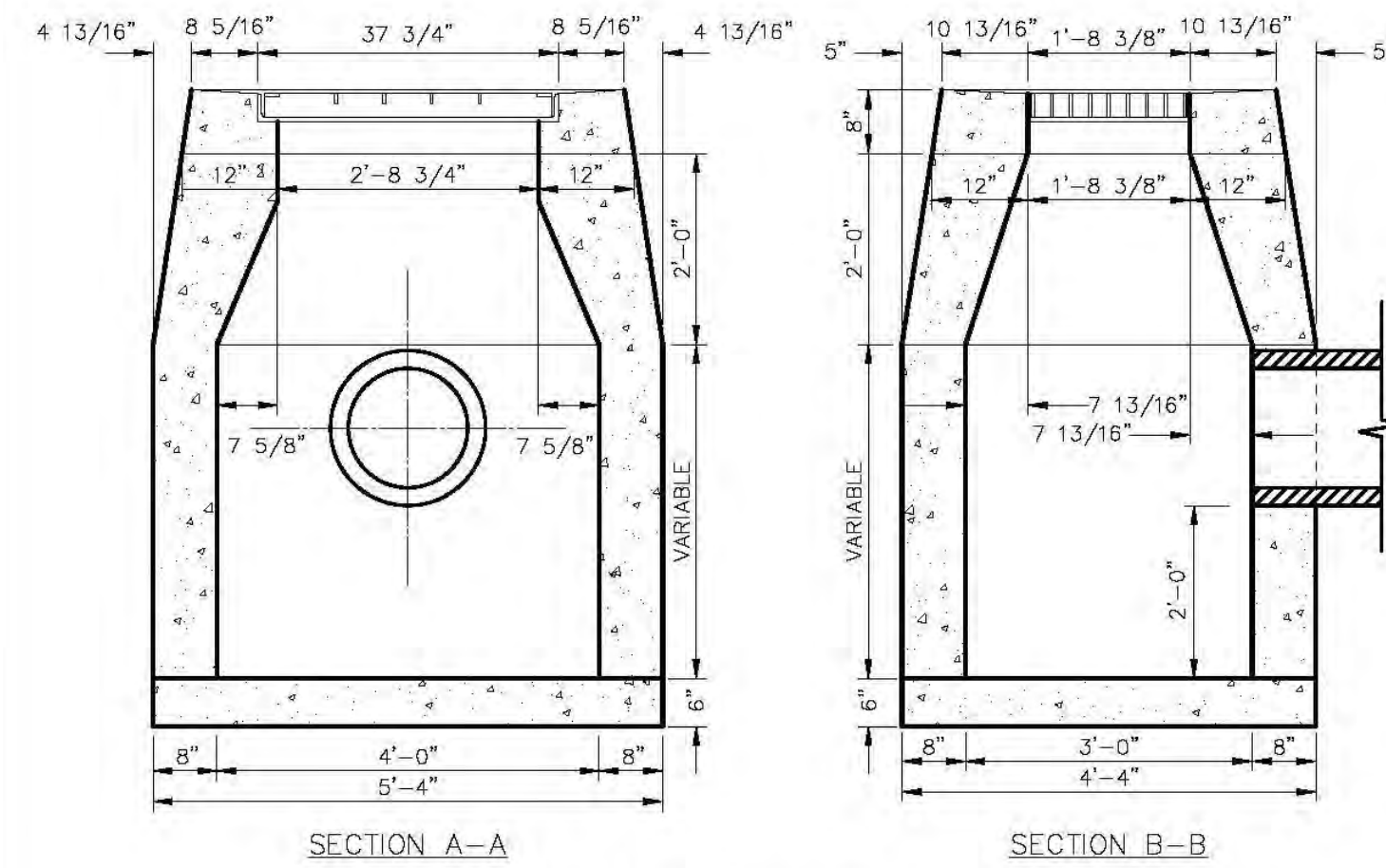

**TYPE "C-L" CATCH BASIN DETAIL**  
NOT TO SCALE

**WATER SERVICE TRENCH DETAIL**

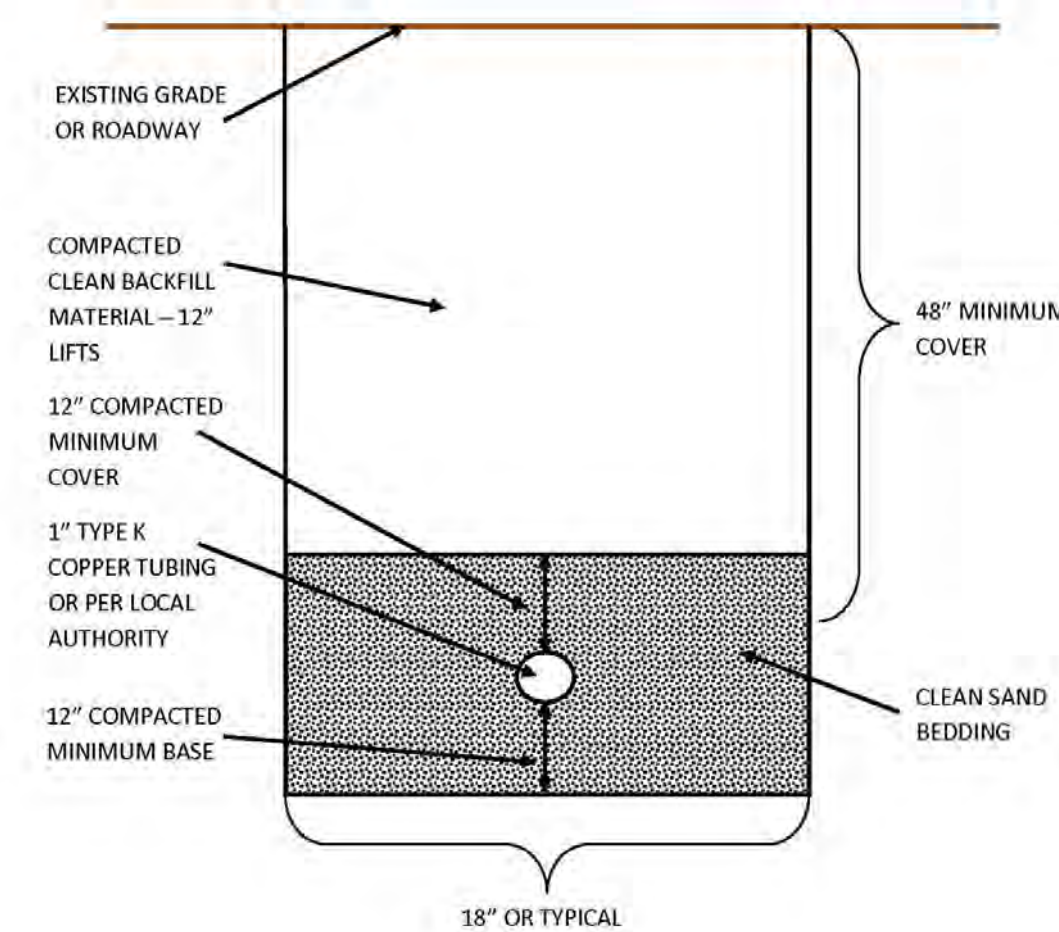

- NOTES:**
1. SIZE OF SERVICE TO BE DETERMINED BY NEEDS OF STRUCTURE AND CUSTOMER. TYPICAL RESIDENTIAL CONNECTION DEPICTED.
  2. CONNECTION TO WATER MAIN AND CONFIGURATION OF THE SERVICE METER/VALVING SHALL BE MADE PER SPECIFICATIONS OF LOCAL WATER UTILITY. TYPICALLY SADDLE TAP FITTING AND CORPORATION STOP, SHUT OFF VALVE AND WATER METER.

**ELECTRIC/COMMUNICATION UTILITY TRENCH**

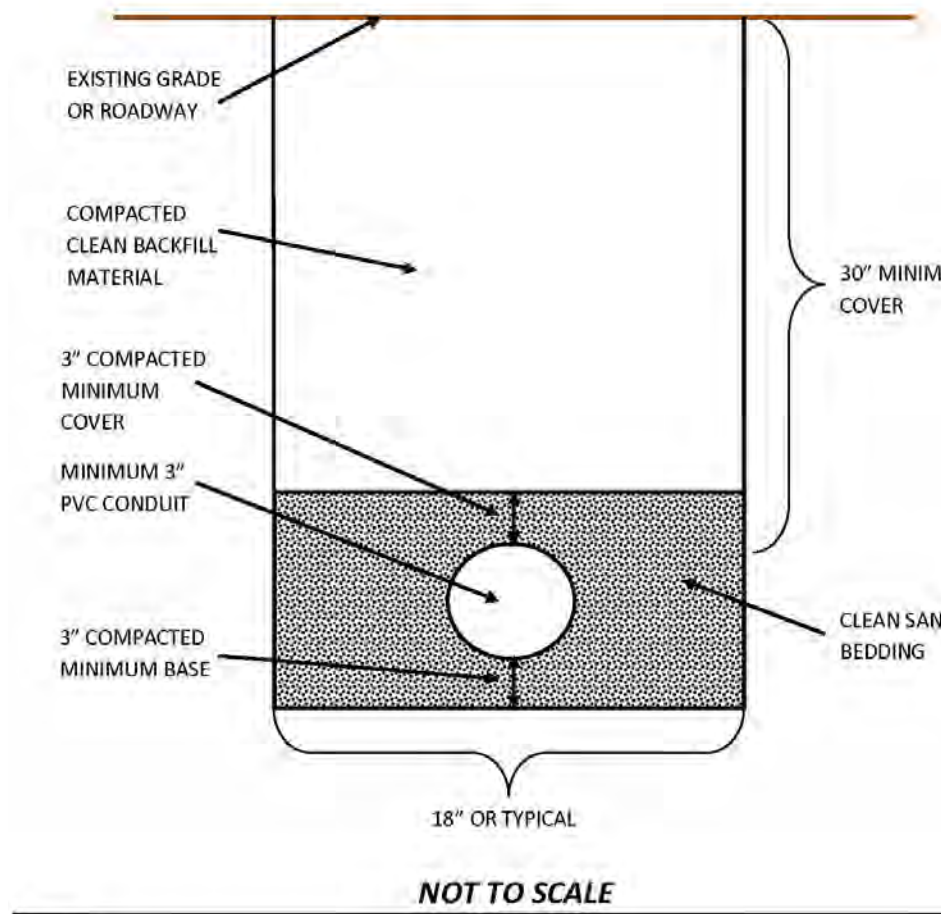

- NOTES:**
1. CONDUIT AND SERVICE CONNECTIONS TO BE MADE PER LOCAL UTILITY SPECIFICATIONS AND REQUIREMENTS.

**SANITARY SEWER SERVICE TRENCH DETAIL**

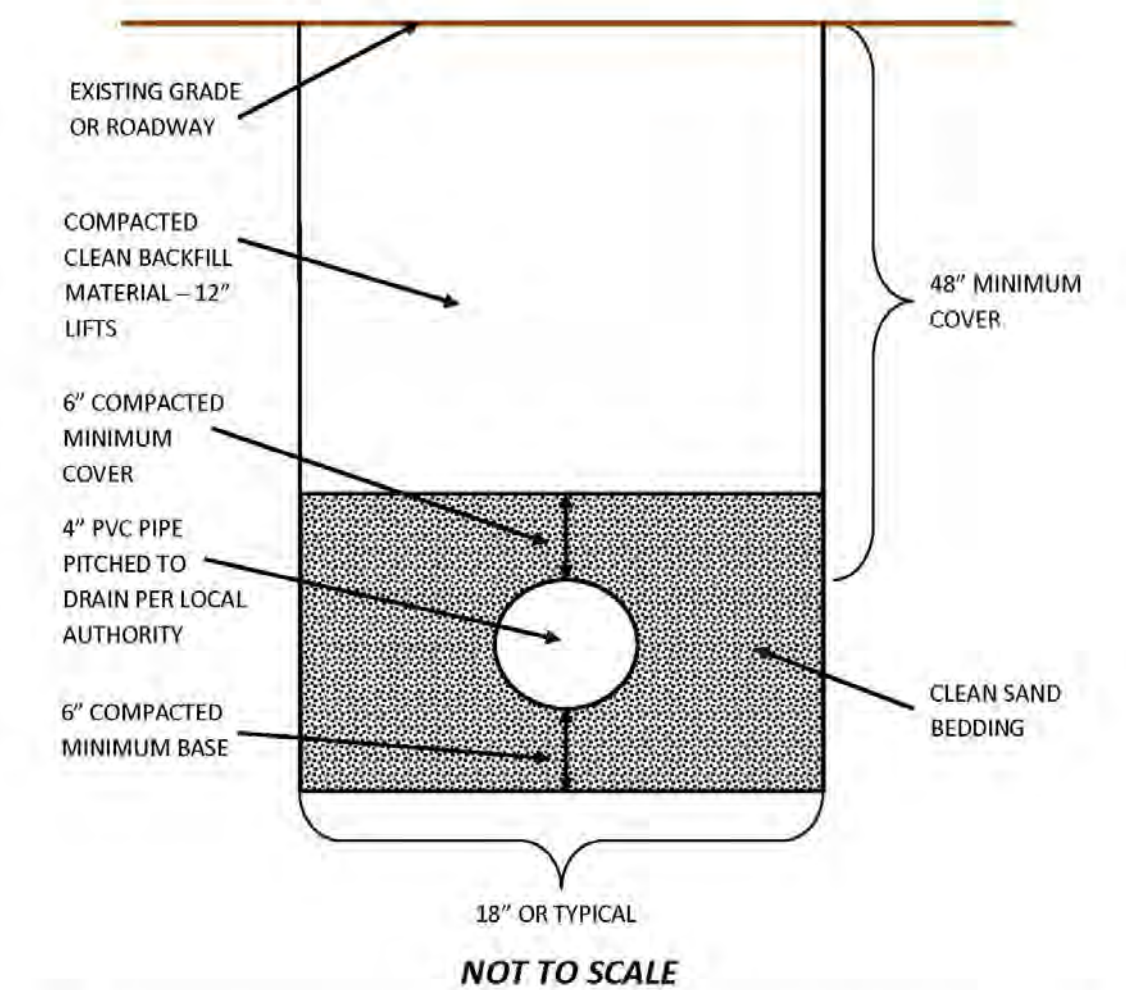

- NOTES:**
1. SIZE OF SERVICE TO BE DETERMINED BY NEEDS OF STRUCTURE AND CUSTOMER. TYPICAL RESIDENTIAL CONNECTION DEPICTED.
  2. CONNECTION TO EXISTING SEWER LATERAL. CONFIGURATION OF THE SERVICE SHALL BE MADE PER SPECIFICATIONS OF LOCAL WATER UTILITY.

**RESUBDIVISION PLAN  
DETAILS & TYPICALS**  
PROPERTY BELONGING TO:  
**MICHAEL A. DESAUTELS**  
**CHESTERFIELD ROAD**  
**MONTVILLE, CONNECTICUT**  
JUNE 10, 2024  
REVISED THROUGH: AUGUST 24, 2025

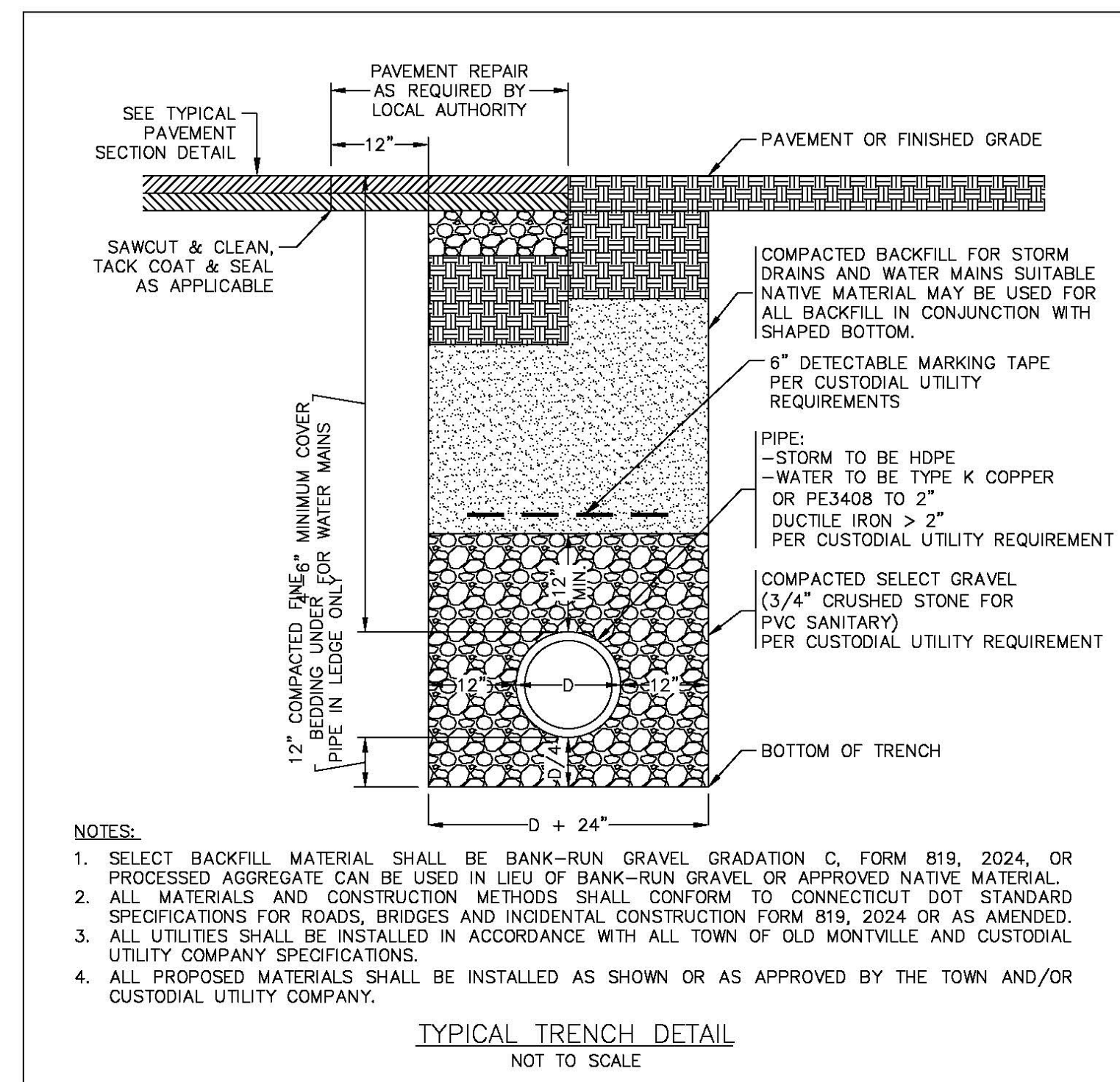
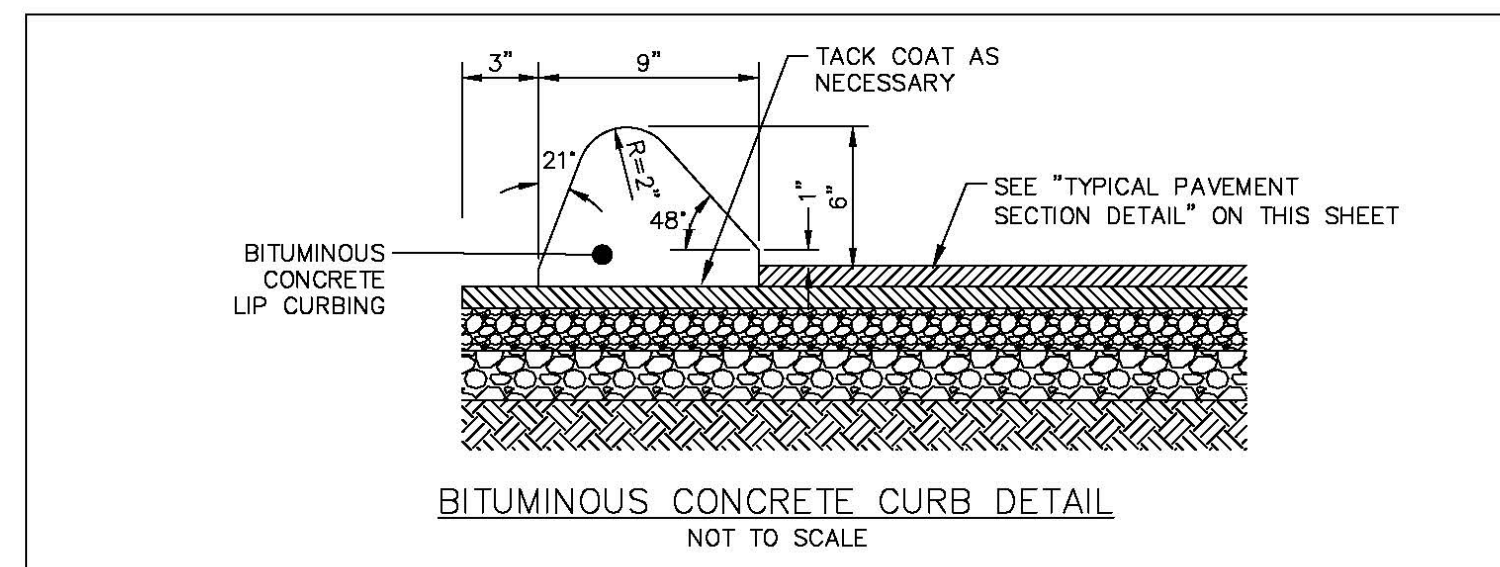
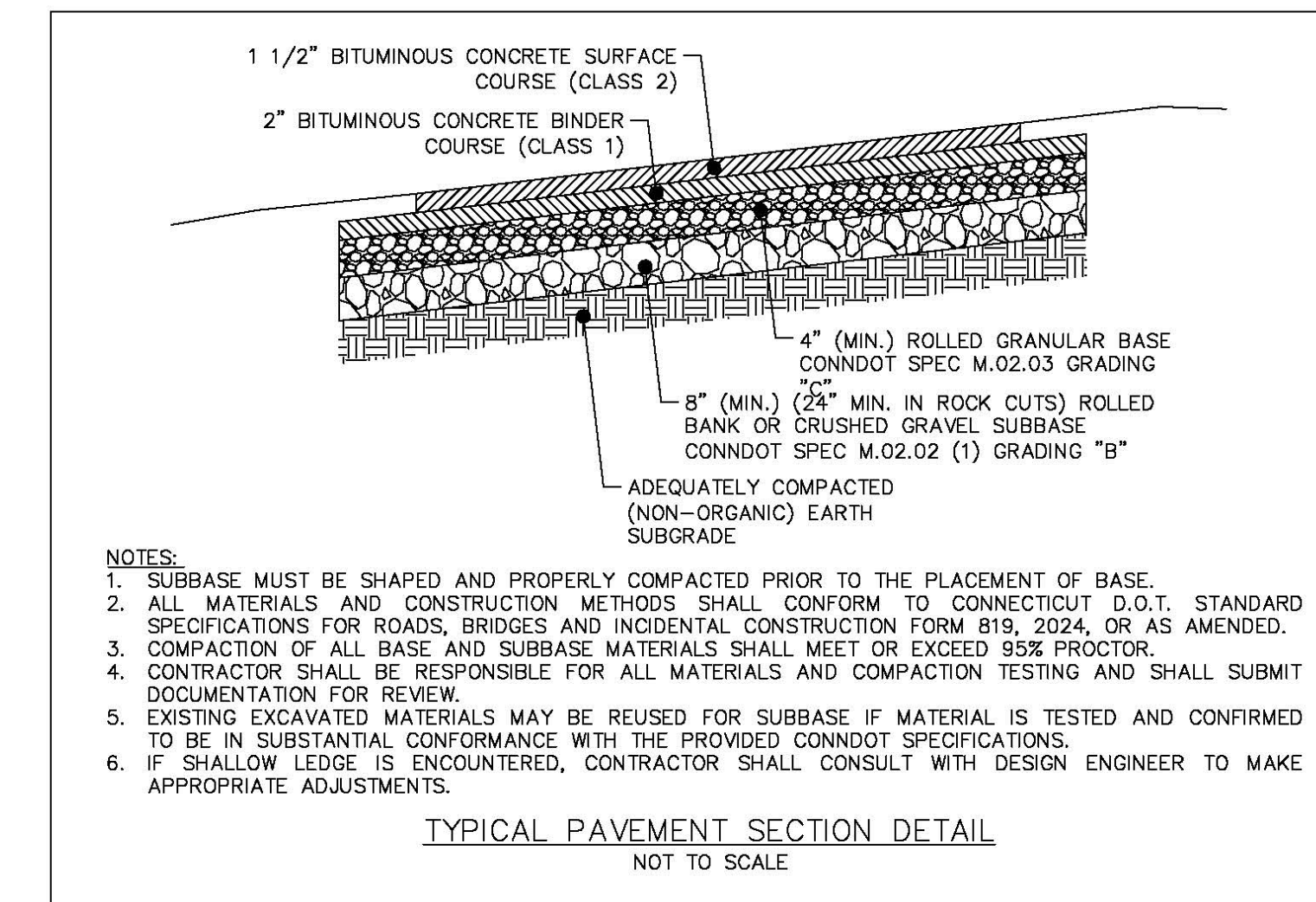
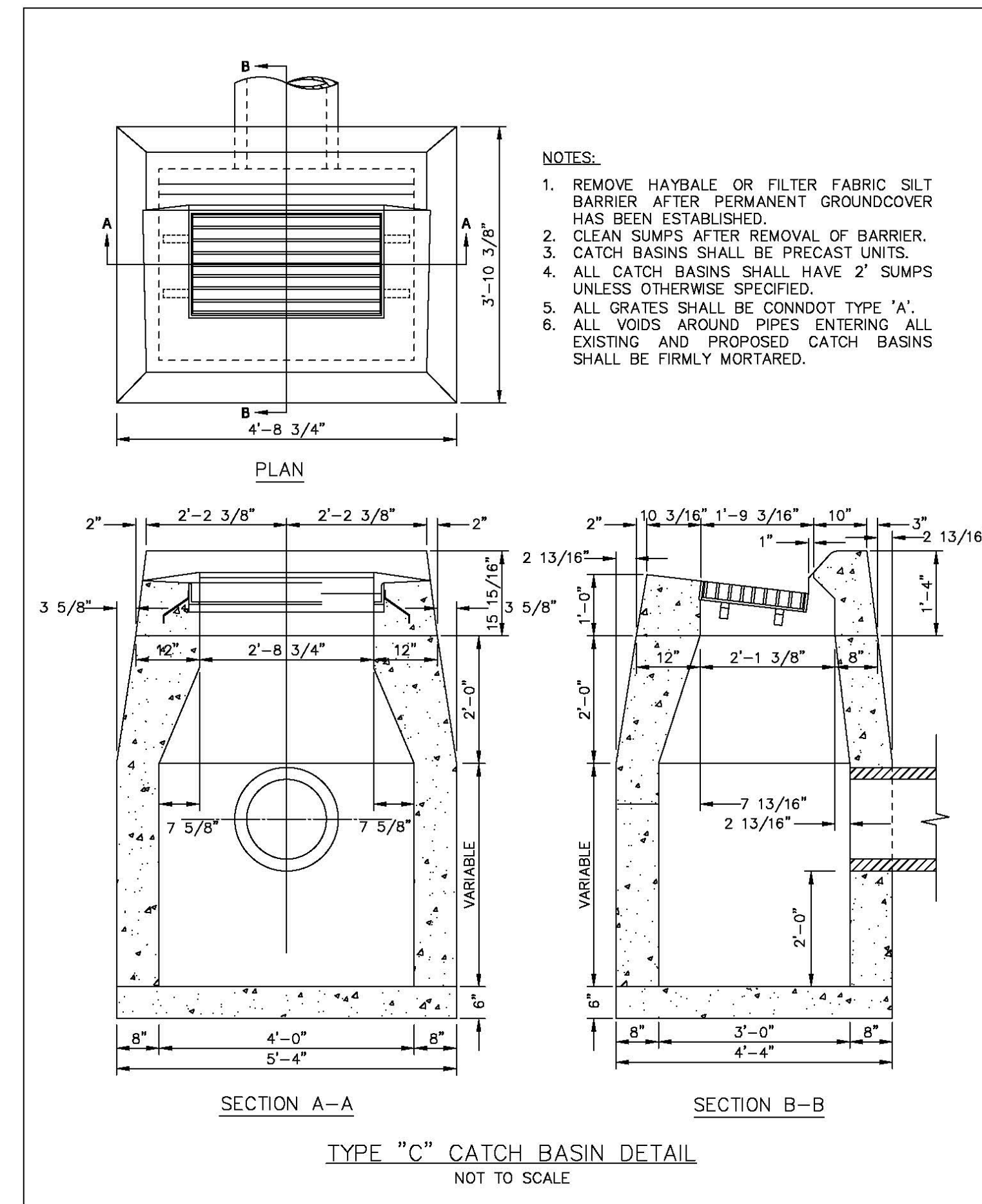
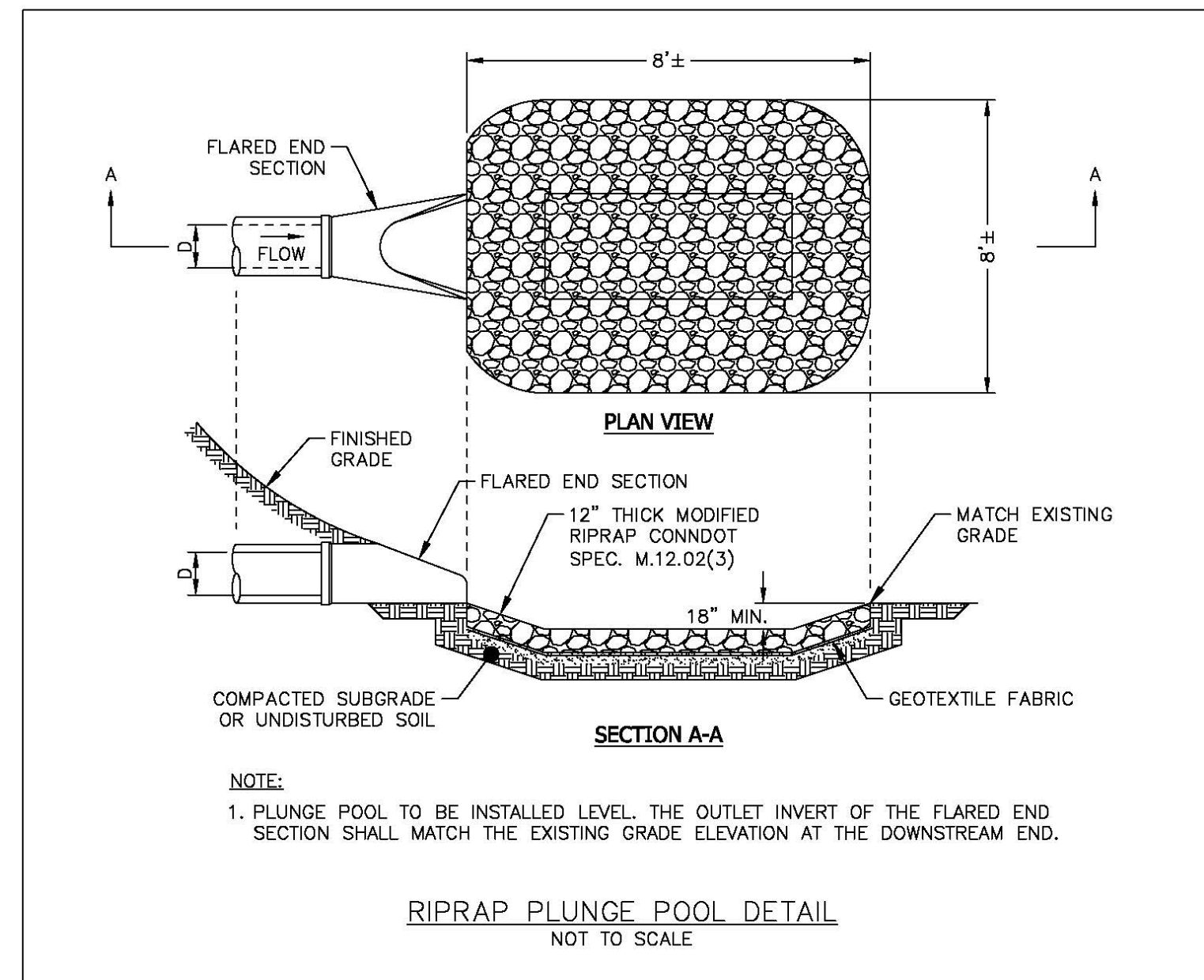

**RESUBDIVISION PLAN**  
**DETAILS & TYPICALS**  
 PROPERTY BELONGING TO:  
**MICHAEL A. DESAUTELS**  
**CHESTERFIELD ROAD**  
**MONTVILLE, CONNECTICUT**  
 JUNE 10, 2024  
 REVISED THROUGH: AUGUST 24, 2025