



Company :
 Designer :
 Job Number :
 Model Name :

8/14/2025
 11:53:40 AM
 Checked By :

Node Reactions (Continued)

	LC	Node Label	X [lb]	Y [lb]	Z [lb]	MX [k-ft]	MY [k-ft]	MZ [k-ft]
242	49	N5	335.648	704.531	1142.37	-0.954	0	0.089
243	49	N103	0.013	43.959	0.02	0	0	0
244	49	Totals:	0	1455.091	0.004			
245	49	COG (ft):	X: 0.584	Y: -1.749	Z: 3.139			
246	50	N6	219.093	701.286	-1142.936	-0.942	0	-0.088
247	50	N5	-219.003	709.844	1143.074	-0.962	0	-0.088
248	50	N103	-0.09	43.959	-0.137	0	0	0
249	50	Totals:	0	1455.088	0.001			
250	50	COG (ft):	X: -1.092	Y: -1.749	Z: 3.139			
251	51	N6	-391.75	597.442	-955.518	-0.801	0	0.106
252	51	N5	391.721	611.382	955.477	-0.831	0	0.105
253	51	N103	0.029	51.285	0.045	0	0	0
254	51	Totals:	0	1260.11	0.004			
255	51	COG (ft):	X: 0.786	Y: -1.141	Z: 2.956			
256	52	N6	-342.948	530.584	-779.844	-0.714	0	0.098
257	52	N5	351.758	542.026	884.431	-0.738	0	0.097
258	52	N103	-8.809	45.504	-9.534	0	0	0
259	52	Totals:	0.002	1118.114	95.053			
260	52	COG (ft):	X: 0.786	Y: -1.141	Z: 2.956			
261	53	N6	-368.67	530.331	-782.079	-0.714	0	0.101
262	53	N5	344.417	542.282	893.504	-0.739	0	0.101
263	53	N103	-23.268	45.501	-29.108	0	0	0
264	53	Totals:	-47.522	1118.114	82.317			
265	53	COG (ft):	X: 0.786	Y: -1.141	Z: 2.956			
266	54	N6	-388.741	529.979	-801.934	-0.713	0	0.102
267	54	N5	337.915	542.635	890.333	-0.74	0	0.102
268	54	N103	-31.484	45.499	-40.868	0	0	0
269	54	Totals:	-82.309	1118.114	47.53			
270	54	COG (ft):	X: 0.786	Y: -1.141	Z: 2.956			
271	55	N6	-397.787	529.624	-834.095	-0.711	0	0.102
272	55	N5	333.997	542.99	875.77	-0.74	0	0.101
273	55	N103	-31.256	45.5	-41.668	0	0	0
274	55	Totals:	-95.046	1118.114	0.006			
275	55	COG (ft):	X: 0.786	Y: -1.141	Z: 2.956			
276	56	N6	-393.377	529.359	-869.941	-0.71	0	0.099
277	56	N5	333.714	543.252	853.719	-0.739	0	0.098
278	56	N103	-22.648	45.502	-31.297	0	0	0
279	56	Totals:	-82.311	1118.113	-47.519			
280	56	COG (ft):	X: 0.786	Y: -1.141	Z: 2.956			
281	57	N6	-376.694	529.258	-899.86	-0.708	0	0.094
282	57	N5	337.142	543.351	830.09	-0.738	0	0.094
283	57	N103	-7.972	45.505	-12.537	0	0	0
284	57	Totals:	-47.524	1118.113	-82.308			
285	57	COG (ft):	X: 0.786	Y: -1.141	Z: 2.956			
286	58	N6	-352.204	529.346	-915.843	-0.708	0	0.09
287	58	N5	343.36	543.26	811.206	-0.738	0	0.09
288	58	N103	8.844	45.507	9.591	0	0	0
289	58	Totals:	-0.001	1118.113	-95.046			
290	58	COG (ft):	X: 0.786	Y: -1.141	Z: 2.956			
291	59	N6	-326.473	529.601	-913.601	-0.708	0	0.087
292	59	N5	350.7	543.003	802.129	-0.737	0	0.086
293	59	N103	23.295	45.509	29.161	0	0	0
294	59	Totals:	47.523	1118.113	-82.31			
295	59	COG (ft):	X: 0.786	Y: -1.141	Z: 2.956			
296	60	N6	-306.399	529.954	-893.745	-0.708	0	0.085

Node Reactions (Continued)

	LC	Node Label	X [lb]	Y [lb]	Z [lb]	MX [k-ft]	MY [k-ft]	MZ [k-ft]
297	60	N5	357.195	542.65	805.29	-0.736	0	0.085
298	60	N103	31.513	45.509	40.932	0	0	0
299	60	Totals:	82.31	1118.113	-47.523			
300	60	COG (ft):	X: 0.786	Y: -1.141	Z: 2.956			
301	61	N6	-297.359	530.309	-861.591	-0.71	0	0.086
302	61	N5	361.109	542.295	819.846	-0.736	0	0.086
303	61	N103	31.297	45.509	41.747	0	0	0
304	61	Totals:	95.047	1118.113	0.001			
305	61	COG (ft):	X: 0.786	Y: -1.141	Z: 2.956			
306	62	N6	-301.778	530.571	-825.753	-0.712	0	0.089
307	62	N5	361.392	542.033	841.901	-0.737	0	0.089
308	62	N103	22.697	45.509	31.378	0	0	0
309	62	Totals:	82.311	1118.113	47.526			
310	62	COG (ft):	X: 0.786	Y: -1.141	Z: 2.956			
311	63	N6	-318.464	530.672	-795.834	-0.713	0	0.093
312	63	N5	357.97	541.935	865.541	-0.738	0	0.093
313	63	N103	8.018	45.507	12.608	0	0	0
314	63	Totals:	47.525	1118.113	82.315			
315	63	COG (ft):	X: 0.786	Y: -1.141	Z: 2.956			
316	64	N6	-235.288	366.3	-517.457	-0.493	0	0.069
317	64	N5	244.11	374.331	622.061	-0.51	0	0.068
318	64	N103	-8.821	31.42	-9.553	0	0	0
319	64	Totals:	0.001	772.051	95.052			
320	64	COG (ft):	X: 0.786	Y: -1.141	Z: 2.956			
321	65	N6	-260.99	366.041	-519.707	-0.493	0	0.072
322	65	N5	236.75	374.592	631.151	-0.511	0	0.072
323	65	N103	-23.282	31.418	-29.129	0	0	0
324	65	Totals:	-47.522	772.051	82.316			
325	65	COG (ft):	X: 0.786	Y: -1.141	Z: 2.956			
326	66	N6	-281.056	365.685	-539.568	-0.493	0	0.073
327	66	N5	230.245	374.95	627.986	-0.512	0	0.073
328	66	N103	-31.498	31.417	-40.889	0	0	0
329	66	Totals:	-82.309	772.051	47.529			
330	66	COG (ft):	X: 0.786	Y: -1.141	Z: 2.956			
331	67	N6	-290.113	365.326	-571.723	-0.491	0	0.073
332	67	N5	226.338	375.308	613.418	-0.512	0	0.072
333	67	N103	-31.271	31.417	-41.69	0	0	0
334	67	Totals:	-95.046	772.051	0.005			
335	67	COG (ft):	X: 0.786	Y: -1.141	Z: 2.956			
336	68	N6	-285.728	365.062	-607.552	-0.489	0	0.07
337	68	N5	226.08	375.571	591.35	-0.511	0	0.07
338	68	N103	-22.662	31.419	-31.318	0	0	0
339	68	Totals:	-82.311	772.051	-47.52			
340	68	COG (ft):	X: 0.786	Y: -1.141	Z: 2.956			
341	69	N6	-269.078	364.962	-637.45	-0.488	0	0.065
342	69	N5	229.539	375.668	567.698	-0.51	0	0.065
343	69	N103	-7.985	31.421	-12.557	0	0	0
344	69	Totals:	-47.524	772.051	-82.309			
345	69	COG (ft):	X: 0.786	Y: -1.141	Z: 2.956			
346	70	N6	-244.619	365.056	-653.41	-0.487	0	0.061
347	70	N5	235.786	375.573	548.791	-0.509	0	0.061
348	70	N103	8.832	31.422	9.573	0	0	0
349	70	Totals:	-0.001	772.051	-95.047			
350	70	COG (ft):	X: 0.786	Y: -1.141	Z: 2.956			
351	71	N6	-218.908	365.316	-651.153	-0.487	0	0.058

Node Reactions (Continued)

	LC	Node Label	X [lb]	Y [lb]	Z [lb]	MX [k-ft]	MY [k-ft]	MZ [k-ft]
352	71	N5	243.145	375.311	539.696	-0.509	0	0.057
353	71	N103	23.285	31.423	29.145	0	0	0
354	71	Totals:	47.522	772.051	-82.312			
355	71	COG (ft):	X: 0.786	Y: -1.141	Z: 2.956			
356	72	N6	-198.839	365.674	-631.291	-0.488	0	0.056
357	72	N5	249.645	374.954	542.85	-0.508	0	0.056
358	72	N103	31.504	31.424	40.917	0	0	0
359	72	Totals:	82.31	772.051	-47.524			
360	72	COG (ft):	X: 0.786	Y: -1.141	Z: 2.956			
361	73	N6	-189.787	366.032	-599.144	-0.49	0	0.057
362	73	N5	253.546	374.596	557.411	-0.508	0	0.057
363	73	N103	31.288	31.424	41.732	0	0	0
364	73	Totals:	95.047	772.051	0			
365	73	COG (ft):	X: 0.786	Y: -1.141	Z: 2.956			
366	74	N6	-194.181	366.294	-563.322	-0.491	0	0.06
367	74	N5	253.804	374.333	579.484	-0.509	0	0.06
368	74	N103	22.687	31.423	31.363	0	0	0
369	74	Totals:	82.311	772.051	47.525			
370	74	COG (ft):	X: 0.786	Y: -1.141	Z: 2.956			
371	75	N6	-210.834	366.392	-533.424	-0.493	0	0.064
372	75	N5	250.352	374.237	603.147	-0.509	0	0.064
373	75	N103	8.007	31.422	12.591	0	0	0
374	75	Totals:	47.525	772.051	82.314			
375	75	COG (ft):	X: 0.786	Y: -1.141	Z: 2.956			

Envelope AISC 15TH (360-16): LRFD Member Steel Code Checks

Member	Shape	Code	Check	Loc(ft)	LC	Shear	Check	Loc(ft)	Dir	LC	phi*	Pnc [lb]	phi*	Pnt [lb]	phi*	Mn y-y [k-ft]	phi*	Mn z-z [k-ft]	Cb	Eqn
1	M2	PL5/8X3.5	0.123	0.39	20	0.122	0.39	y	8	67909.55	68906.25	0.897	5.024	1.684	H1-1b					
2	M4	PL5/8X3.5	0.139	0.39	8	0.144	0.39	y	2	67909.55	68906.25	0.897	5.024	1.684	H1-1b					
3	M6	PL5/8X3.5	0.214	0	26	0.094	0.072	y	1	67909.55	68906.25	0.897	5.024	1.684	H1-1b					
4	M8	PL5/8X3.5	0.203	0	1	0.16	0.072	y	7	67909.55	68906.25	0.897	5.024	1.684	H1-1b					
5	XDARM1-1	PIPE 2.0X	0.177	3.973	27	0.05	3.973	50	40578.803	44100	2.531	2.531	1	H1-1b						
6	XDARM1-2	PIPE 2.0X	0.184	3.973	33	0.051	3.973	50	40578.803	44100	2.531	2.531	1	H1-1b						
7	XDARM2-2	PIPE 2.0X	0.207	3.869	25	0.103	3.973	26	40578.803	44100	2.531	2.531	1	H1-1b						
8	XDARM2-1	PIPE 2.0X	0.206	3.869	29	0.102	3.973	25	40578.803	44100	2.531	2.531	1	H1-1b						
9	VB1-1	SR 0.625	0.058	1.875	8	0.013	3.75	31	2880.354	9664.074	0.101	0.101	1	H1-1b						
10	VB1-2	SR 0.625	0.047	1.875	8	0.029	3.75	27	2880.354	9664.074	0.101	0.101	1	H1-1b						
11	VB2-2	SR 0.625	0.053	1.875	7	0.025	3.75	26	2880.354	9664.074	0.101	0.101	1	H1-1b						
12	VB2-1	SR 0.625	0.054	1.875	12	0.011	3.75	32	2880.354	9664.074	0.101	0.101	1	H1-1b						
13	DB2-2	SR 0.75	0.117	2.603	13	0.012	5.205	2	2074.5	13916.274	0.174	0.174	1	H1-1b						
14	DB2-1	SR 0.75	0.69	2.466	26	0.01	5.205	36	2074.5	13916.274	0.174	0.174	1	H1-1a						
15	DB1-1	SR 0.75	0.093	2.603	13	0.008	5.205	11	2074.5	13916.274	0.174	0.174	1	H1-1b						
16	DB1-2	SR 0.75	0.339	2.74	50	0.006	5.205	12	2074.5	13916.274	0.174	0.174	1	H1-1a						
17	M37	PL5/8X3.5	0.322	0.636	50	0.105	0.636	y	8	62872.952	68906.25	0.897	5.024	1.565	H1-1b					
18	M38	PL5/8X3.5	0.743	0	30	0.117	0	y	30	62872.952	68906.25	0.897	5.024	1.388	H1-1b					
19	M39	PL5/8X3.5	0.322	0.636	50	0.07	0.636	y	8	62872.952	68906.25	0.897	5.024	1.575	H1-1b					
20	M40	PL5/8X3.5	0.741	0	26	0.111	0.636	y	30	62872.952	68906.25	0.897	5.024	1.388	H1-1b					
21	M44	PIPE 2.5	0.253	3.079	2	0.102	2.737	2	46759.67	50715	3.596	3.596	1	H1-1b						
22	M45	PIPE 2.5	0.321	3.079	8	0.082	10.263	30	46759.67	50715	3.596	3.596	1	H1-1b						
23	MP1A	PIPE 2.0	0.305	2.316	31	0.048	5.895	6	3485.189	32130	1.872	1.872	1	H1-1b						
24	MP2A	PIPE 2.0	0.125	2.105	1	0.041	5.684	26	3485.189	32130	1.872	1.872	1	H1-1b						
25	MP3A	PIPE 2.0	0.167	5.684	26	0.051	4	2	3485.189	32130	1.872	1.872	1	H1-1b						
26	MP4A	PIPE 2.0	0.256	4.842	2	0.115	2.316	2	3485.189	32130	1.872	1.872	1	H1-1b						
27	OVP	PIPE 2.0	0.048	1.053	11	0.023	0.211	8	26521.424	32130	1.872	1.872	1	H1-1b						
28	M46	PIPE 2.5	0.105	6.687	9	0.006	13.373	15	12719.785	50715	3.596	3.596	1	H1-1b						

I. Mount-to-Tower Connection Check

Custom Orientation Required

Yes

Nodes (labeled per Risa)	Orientation (per graphic of typical platform)
N6	25
N5	25

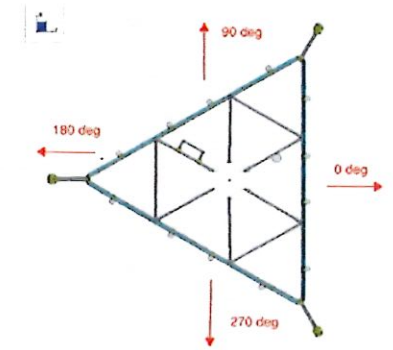

Tower Connection Bolt Checks

Yes

Bolt Orientation

Parallel

Bolt Quantity per Reaction:	4
d_x (in) (Delta X of typ. bolt config. sketch):	9.5
d_y (in) (Delta Y of typ. bolt config. sketch):	3.5
Bolt Type:	A325N
Bolt Diameter (in):	0.625
Required Tensile Strength / bolt (kips):	2.8
Required Shear Strength / bolt (kips):	0.5
Tensile Capacity / bolt (kips):	20.7
Shear Capacity / bolt (kips):	12.4
Bolt Overall Utilization:	13.8%

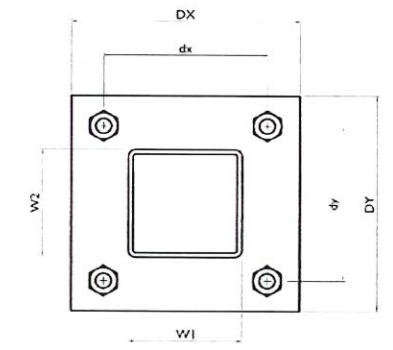

Tower Connection Baseplate Checks

No

ATTACHMENT 4



C Squared Systems, LLC
65 Dartmouth Drive
Auburn, NH 03032
(603) 644-2800
support@csquaredsystems.com

Calculated Radio Frequency Emissions Report



Montville West
401 Chapel Hill Road, Montville, CT

November 20, 2025

Table of Contents

1. Introduction 1

2. FCC Guidelines for Evaluating RF Radiation Exposure Limits 1

3. RF Exposure Prediction Methods 2

4. Antenna Inventory 3

5. Calculation Results 4

6. Conclusion 6

7. Statement of Certification 6

Attachment A: References 7

Attachment B: FCC Limits for Maximum Permissible Exposure (MPE) 8

Attachment C: Verizon Antenna Model Data Sheets and Electrical Patterns 10

List of Figures

Figure 1: Graph of General Population % MPE vs. Distance 4

Figure 2: Graph of FCC Limits for Maximum Permissible Exposure (MPE) 9

List of Tables

Table 1: Proposed Antenna Inventory, 3

Table 2: Maximum Percent of General Population Exposure Values, 5

Table 3: FCC Limits for Maximum Permissible Exposure 8

1. Introduction

The purpose of this report is to investigate compliance with applicable FCC regulations for the proposed installation of Verizon's antenna arrays to be mounted at 160' above ground level (AGL) on the existing self-support tower located at 401 Chapel Hill Road, Montville, CT. The coordinates of the facility are 41° 28' 7.67" N, 72° 12' 11.56" W.

Verizon is proposing to install nine (9) directional antennas (three sectors, three antennas per sector) to support its 4G LTE and 5G NR networks.

This report considers the proposed antenna configuration for Verizon, in addition to equipment configurations from operators that are currently located on the existing self-support tower, to calculate the resulting percentage of Maximum Permissible Exposure (% MPE) at ground level around the existing facility. The other operators on site include T-Mobile, Calvary Chapel, Tactical Communications and U.S. Coast Guard. The technical operating information for the existing operators at this facility was based on prior Connecticut Siting Council (CSC) application on record¹ and reasonable assumptions when the information is unavailable.

2. FCC Guidelines for Evaluating RF Radiation Exposure Limits

In 1985, the FCC established rules to regulate radio frequency (RF) exposure from FCC licensed antenna facilities. In 1996, the FCC updated these rules, which were further amended in August 1997 by OET Bulletin 65 Edition 97-01. These new rules include Maximum Permissible Exposure (MPE) limits for transmitters operating between 300 kHz and 100 GHz. The FCC MPE limits are based upon those recommended by the National Council on Radiation Protection and Measurements (NCRP), developed by the Institute of Electrical and Electronics Engineers, Inc., (IEEE) and adopted by the American National Standards Institute (ANSI).

The FCC general population/uncontrolled limits set the maximum exposure to which most people may be subjected. General population/uncontrolled exposures apply in situations in which the general public may be exposed, or in which persons that are exposed as a consequence of their employment may not be fully aware of the potential for exposure or cannot exercise control over their exposure.

Public exposure to radio frequencies is regulated and enforced in units of milliwatts per square centimeter (mW/cm²). The general population exposure limits for the various frequency ranges are defined in the documents referenced in Attachment A of this report.

Higher exposure limits are permitted under the occupational/controlled exposure category, but only for persons who are exposed as a consequence of their employment and who have been made fully aware of the potential for exposure, and they must be able to exercise control over their exposure. General population/uncontrolled limits are five times more stringent than the levels that are acceptable for occupational, or radio frequency trained individuals. Attachment B contains excerpts from OET Bulletin 65 and defines the Maximum Exposure Limit.

Finally, it should be noted that the MPE limits adopted by the FCC for both general population/uncontrolled exposure and for occupational/controlled exposure incorporate a substantial margin of safety and have been established to be well below levels generally accepted as having the potential to cause adverse health effects.

¹ As referenced to T-Mobile's Connecticut Siting Council Notice of Exempt Modification – 401 Chapel Hill Road, Oakdale, CT, dated 5/13/2021.

3. RF Exposure Prediction Methods

The results displayed in the following figures were generated using the following formula as outlined in FCC bulletin OET 65:

$$\text{Power Density} = \left(\frac{\text{GRF}^2 \times \text{EIRP}}{4\pi \times R^2} \right) \times \text{Off Beam Loss}$$

Where:

EIRP = Effective Isotropic Radiated Power

R = Radial Distance = $\sqrt{H^2 + V^2}$

H = Horizontal Distance from antenna

V = Vertical Distance from center of antenna

Off Beam Loss is determined by the selected antenna patterns

GRF = Ground reflection factor of 1.6

These calculations assume that the antennas are operating at full power and 100 percent capacity, and that all antenna channels are transmitting simultaneously. Obstructions (trees, buildings, etc.) that would normally attenuate the signal are not considered. As a result, the calculated power density and corresponding % MPE levels reported below are more conservative (higher) than the actual signal levels will be from the final installation.

The percent of MPE values presented in this report reflect levels that one may encounter from one sector of a carrier's antennas. Most carriers use 3 or 4 sectors per site with azimuths approximately 90 or 120 degrees apart, respectively; therefore, one could not be standing in the main beam of multiple sectors at the same time. In cases where antenna models are not uniform across all sectors, the antenna model with the highest gain and/or electrical down-tilt was used for the calculations. This results in a conservative or "worst case" assumption for percent of MPE calculations.

4. Antenna Inventory

Table 1 below outlines the proposed antenna configuration for Verizon. The associated data model and antenna patterns for these specific antenna models are included in Attachments C.

Operator	Sector / Azimuth	TX Freq (MHz)	Power at Antenna (Watts)	Ant Gain (dBi)	Power EIRP (Watts)	Antenna Model	Beam Width	Mech. / Elec. Tilt	Length (ft)	Antenna Centerline Height (ft)
Verizon	Alpha / 50°	750	160	15.5	5677	MX06FHG665-HG	67	0/0	6	160
		850	160	16	6370		64	0/2		
		1900	320	19	25419		64	0/2		
		2100	320	19.6	29184		64	0/2		
		3700	320	25.5	113540	MT6413-77A	-	0/1	2.46	160
	Beta / 170°	750	160	15.5	5677	MX06FHG665-HG	67	0/0	6	160
		850	160	16	6370		64	0/2		
		1900	320	19	25419		64	0/2		
		2100	320	19.6	29184		64	0/2		
		3700	320	25.5	113540	MT6413-77A	-	0/1	2.46	160
	Gamma / 290°	750	160	15.5	5677	MX06FHG665-HG	67	0/0	6	160
		850	160	16	6370		64	0/2		
		1900	320	19	25419		64	0/2		
		2100	320	19.6	29184		64	0/2		
		3700	320	25.5	113540	MT6413-77A	-	0/1	2.46	160

Table 1: Proposed Antenna Inventory^{4,5}

⁴ Antenna configuration is in reference to Verizon's Radio Frequency Design Sheet dated 6/27/2025.

⁵ Transmit power assumes 0 dB of cable loss.

5. Calculation Results

The calculated % MPE results for the proposed and existing antenna configuration are shown in Figure 1 below. Each frequency band and technology is calculated as well as the resulting cumulative percent of MPE. For completeness, the calculations for this analysis range from 0 feet horizontal distance (directly below the antennas) to a value of 3,000 feet horizontal distance from the site. In addition to the other worst-case scenario considerations that were previously mentioned, the power density calculations to each horizontal distance point away from the antennas was completed using a local maximum off beam antenna gain (within ± 5 degrees of the true mathematical angle) to incorporate a realistic worst-case scenario.

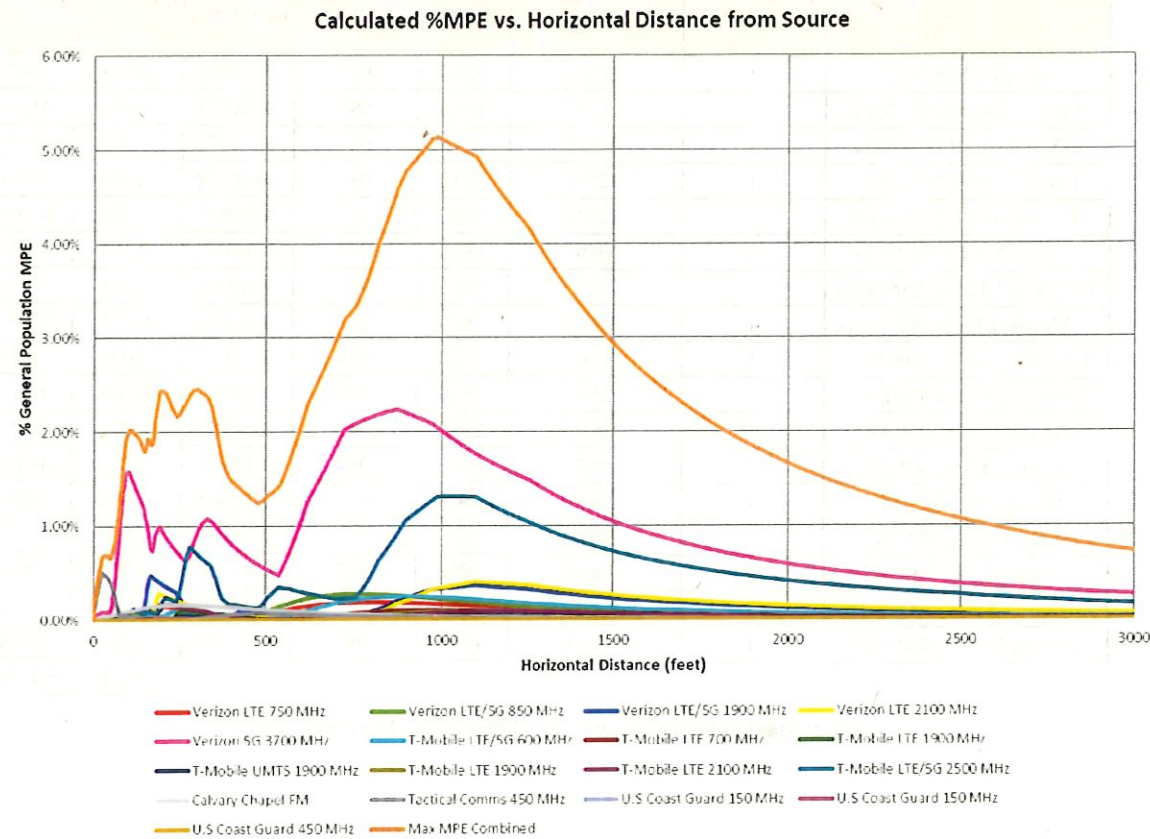

Figure 1: Graph of General Population % MPE vs. Distance

The highest percent of MPE (5.13% of the General Population limit) is calculated to occur at a horizontal distance of 987 feet from antennas. Please note that the percent of MPE calculations close to the site take into account off beam loss, which is determined from the vertical pattern of the antennas used. Therefore, RF power density levels may increase as the distance from the site increases. At distances of approximately 3,000 feet and beyond, one would now be in the main beam of the antenna pattern and off beam loss is no longer considered. Beyond this point, RF levels become calculated solely on distance from the site and the percent of MPE decreases significantly as distance from the site increases.

Table 2 below lists percent of MPE values as well as the associated parameters that were included in the calculations. As stated in Section 3, all calculations assume that the antennas are operating at 100 percent capacity, and that all antenna channels are transmitting simultaneously. Obstructions (trees, buildings etc.) that would normally attenuate the signal are not taken into account. Additionally, a six-foot height offset was considered in this analysis to account for the height of a person standing at ground level. As a result, the calculated % MPE levels are significantly higher than the actual signal levels will be from the final installation. The results presented in Figure 1 and Table 2 assume level ground elevation from the base of the site out to the horizontal distances calculated.

Carrier	Number of Transmitters	Power out of Base Station Per Transmitter (Watts)	Antenna Height (Feet)	Distance to the Base of Antennas (Feet)	Power Density (mW/cm ²)	Limit (mW/cm ²)	% MPE
Calvary Chapel FM	1	283.0	300.0	987	0.000082	0.200	0.04%
Tactical Comms 450 MHz	2	22.4	100.0	987	0.000073	0.300	0.02%
T-Mobile LTE 1900 MHz	1	120.0	180.0	987	0.000672	1.000	0.07%
T-Mobile LTE 1900 MHz	1	120.0	180.0	987	0.000952	1.000	0.10%
T-Mobile LTE 2100 MHz	1	120.0	180.0	987	0.000810	1.000	0.08%
T-Mobile LTE 700 MHz	1	60.0	180.0	987	0.000472	0.467	0.10%
T-Mobile LTE/5G 2500 MHz	1	240.0	180.0	987	0.013106	1.000	1.31%
T-Mobile LTE/5G 600 MHz	1	160.0	180.0	987	0.000978	0.400	0.24%
T-Mobile UMTS 1900 MHz	1	60.0	180.0	987	0.000336	1.000	0.03%
U.S Coast Guard 150 MHz	1	25.0	255.0	987	0.000015	0.200	0.01%
U.S Coast Guard 150 MHz	1	25.0	220.0	987	0.000021	0.200	0.01%
U.S Coast Guard 450 MHz	1	28.0	255.0	987	0.000021	0.200	0.01%
Verizon 5G 3700 MHz	1	320.0	160.0	987	0.020465	1.000	2.05%
Verizon LTE 2100 MHz	1	320.0	160.0	987	0.003337	1.000	0.33%
Verizon LTE 750 MHz	1	160.0	160.0	987	0.000856	0.500	0.17%
Verizon LTE/5G 1900 MHz	1	320.0	160.0	987	0.003297	1.000	0.33%
Verizon LTE/5G 850 MHz	1	160.0	160.0	987	0.001284	0.567	0.23%
						Total	5.13%

Table 2: Maximum Percent of General Population Exposure Values^{6,7,8}

⁶ Frequencies listed are representative of the operating band and are not the specific operating frequency.

⁷ The total % MPE listed is a summation of each unrounded contribution. Therefore, summing each rounded value may not reflect the total value listed in the table.

⁸ For the purpose of this analysis, reasonable assumption of 100 W ERP is used in the calculation for the VHF/UHF antennas used by Tactical Comms., and U.S. Coast Guard.

6. Conclusion

The above analysis concludes that RF exposure levels from the existing site with Verizon's proposed antenna configuration will be well below the maximum permissible levels as outlined by the FCC in the OET Bulletin 65 Ed. 97-01. Using the conservative calculation methods and parameters detailed above, the maximum cumulative percent of MPE in consideration of all transmitters is calculated to be **5.13% of the FCC limit (General Population/Uncontrolled)**. This maximum cumulative percent of MPE value is calculated to occur 987 feet away from the site.

7. Statement of Certification

I certify to the best of my knowledge that the statements in this report are true and accurate. The calculations follow guidelines set forth in ANSI/IEEE Std. C95.3, ANSI/IEEE Std. C95.1 and FCC OET Bulletin 65 Edition 97-01.



Report Prepared By: Ram Acharya
RF Engineer
C Squared Systems, LLC

November 20, 2025

Date



Reviewed/Approved By: Martin Lavin
Senior RF Engineer
C Squared Systems, LLC

November 20, 2025

Date

Attachment A: References

OET Bulletin 65 - Edition 97-01 - August 1997 Federal Communications Commission Office of Engineering & Technology

IEEE C95.1-2019, IEEE Standard Safety Levels With Respect to Human Exposure to Electric, Magnetic, and Electromagnetic Fields, 0 Hz to 300 GHz IEEE-SA Standards Board

IEEE C95.3-2021, IEEE Recommended Practice for Measurements and Computations of Electric, Magnetic, and Electromagnetic Fields with Respect to Human Exposure to Such Fields, 0 Hz-300 GHz IEEE-SA Standards Board

Attachment B: FCC Limits for Maximum Permissible Exposure (MPE)

(A) Limits for Occupational/Controlled Exposure⁹

Frequency Range (MHz)	Electric Field Strength (E) (V/m)	Magnetic Field Strength (E) (A/m)	Power Density (S) (mW/cm ²)	Averaging Time E ² , H ² or S (minutes)
0.3-3.0	614	1.63	(100)*	6
3.0-30	1842/f	4.89/f	(900/f ²)*	6
30-300	61.4	0.163	1.0	6
300-1500	-	-	f/300	6
1500-100,000	-	-	5	6

(B) Limits for General Population/Uncontrolled Exposure¹⁰

Frequency Range (MHz)	Electric Field Strength (E) (V/m)	Magnetic Field Strength (E) (A/m)	Power Density (S) (mW/cm ²)	Averaging Time E ² , H ² or S (minutes)
0.3-1.34	614	1.63	(100)*	30
1.34-30	824/f	2.19/f	(180/f ²)*	30
30-300	27.5	0.073	0.2	30
300-1500	-	-	f/1500	30
1500-100,000	-	-	1.0	30

f = frequency in MHz * Plane-wave equivalent power density

Table 3: FCC Limits for Maximum Permissible Exposure

⁹ Occupational/controlled limits apply in situations in which persons are exposed as a consequence of their employment provided those persons are fully aware of the potential for exposure and can exercise control over their exposure. Limits for occupational/controlled exposure also apply in situations when an individual is transient through a location where occupational/controlled limits apply provided he or she is made aware of the potential for exposure.

¹⁰ General population/uncontrolled exposures apply in situations in which the general public may be exposed, or in which persons that are exposed as a consequence of their employment may not be fully aware of the potential for exposure or cannot exercise control over their exposure.

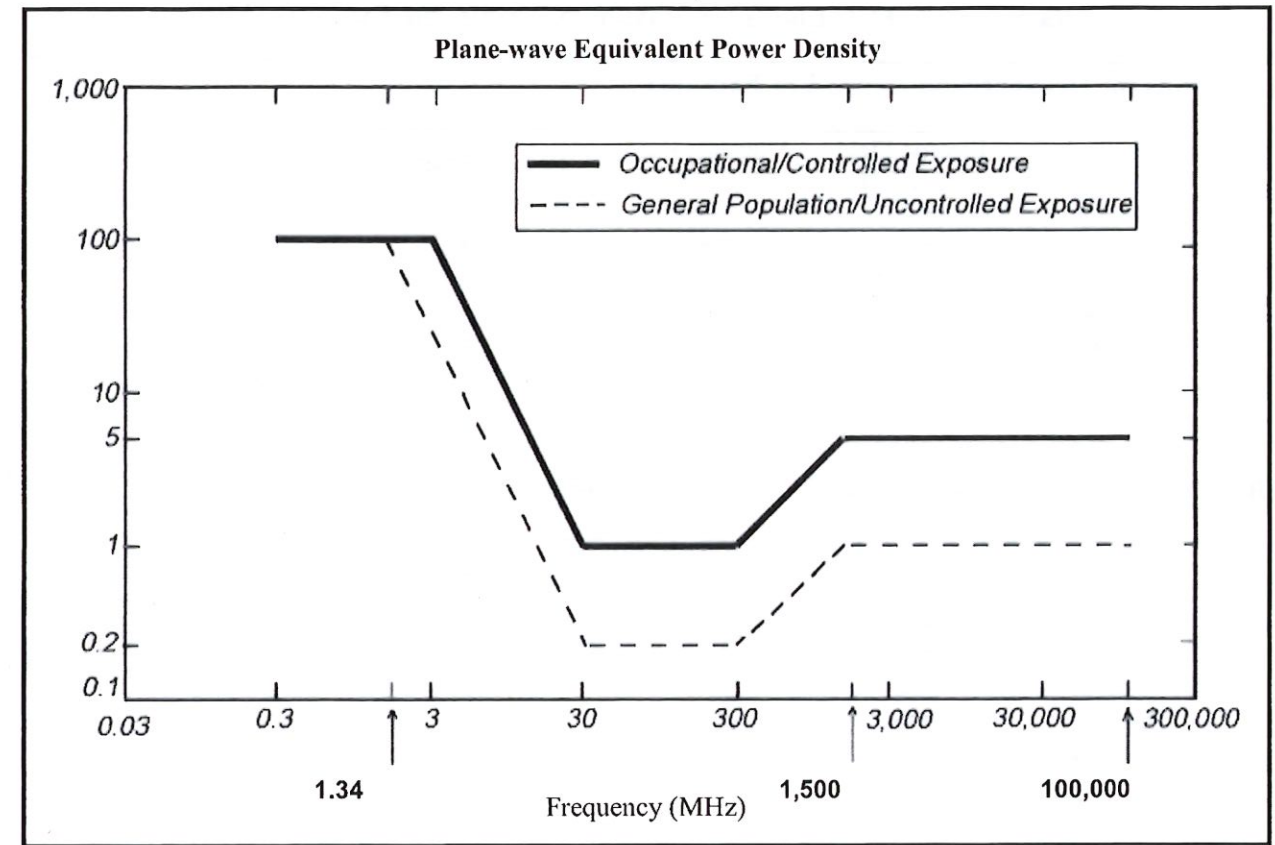
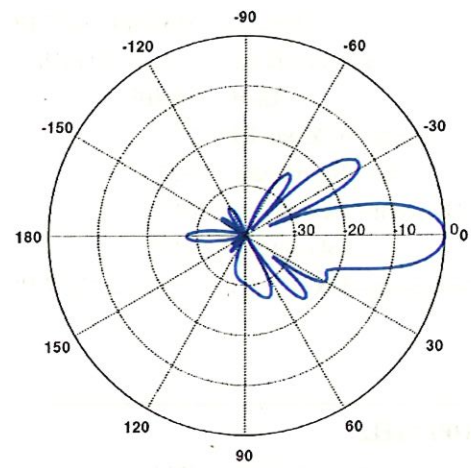

Figure 2: Graph of FCC Limits for Maximum Permissible Exposure (MPE)

Attachment C: Verizon Antenna Model Data and Electrical Patterns

750 MHz

Manufacturer: JMA
 Model #: MX06FHG665-HG
 Frequency Band: 698-798 MHz
 Gain: 15.5 dBi
 Electrical Down-Tilt: 0°
 Vertical Beamwidth: 14°
 Horizontal Beamwidth: 67°
 Polarization: ±45°
 Dimensions (L x W x D): 72" x 12.2" x 7.5"



850 MHz

Manufacturer: JMA
 Model #: MX06FHG665-HG
 Frequency Band: 824-894 MHz
 Gain: 16 dBi
 Electrical Down-Tilt: 2°
 Vertical Beamwidth: 12.5°
 Horizontal Beamwidth: 64°
 Polarization: ±45°
 Dimensions (L x W x D): 72" x 12.2" x 7.5"

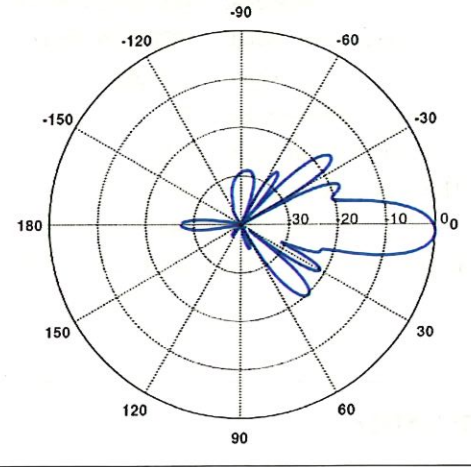

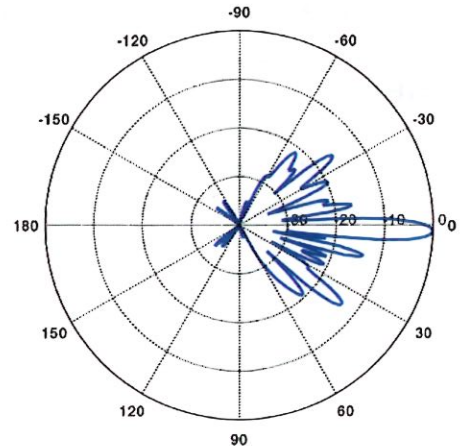
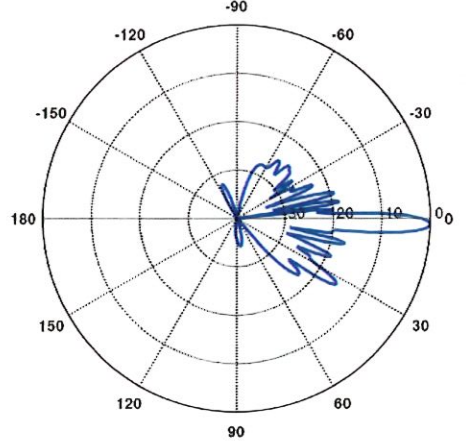
<p>1900 MHz</p> <p>Manufacturer: JMA Model #: MX06FHG665-HG Frequency Band: 1850-1990 MHz Gain: 19 dBi Electrical Down-Tilt: 2° Vertical Beamwidth: 5.5° Horizontal Beamwidth: 64° Polarization: ±45° Dimensions (L x W x D): 72" x 12.2" x 7.5"</p>	
<p>2100 MHz</p> <p>Manufacturer: JMA Model #: MX06FHG665-HG Frequency Band: 1920-2180 MHz Gain: 19.6 dBi Electrical Down-Tilt: 2° Vertical Beamwidth: 5.2° Horizontal Beamwidth: 64° Polarization: ±45° Dimensions (L x W x D): 72" x 12.2" x 7.5"</p>	
<p>3700 MHz</p> <p>Manufacturer: SAMSUNG Model #: MT6413-77A Frequency Band: 3700-3980 MHz Gain: 25.5 dBi Electrical Down-Tilt: 1° Vertical Beamwidth: N/A° Horizontal Beamwidth: N/A° Polarization: N/A° Dimensions (L x W x D): 29.53" x 15.75" x 5.51"</p>	<p>N/A</p>

ATTACHMENT 5

February 2, 2026

Via Certificate of Mailing

Leonard G. Bunnell Sr., Mayor
Town of Montville
310 Norwich-New London Turnpike
Uncasville, CT 06382

Re: Cellco Partnership d/b/a Verizon Wireless – Petition for Declaratory Ruling Filed with the Connecticut Siting Council for the Installation of a Wireless Telecommunications Facility at 401 Chapel Hill Road, Montville, Connecticut

Dear Mayor Bunnell:

This firm represents Cellco Partnership d/b/a Verizon Wireless (“Cellco”). Today, Cellco filed a Petition for Declaratory Ruling (“Petition”) with the Connecticut Siting Council (“Council”) seeking approval for the installation of a wireless telecommunications facility at 401 Chapel Hill Road in Montville (the “Property”).

The proposed Cellco facility will consist of the installation of nine (9) panel type antennas and six (6) remote radio heads at the 160-foot level on the existing 300-foot SubCarrier Communications tower. Equipment associated with the antennas and a diesel-fuel back up generator will be located on the ground near the base of the tower. Installation of the Cellco ground-base equipment and generator will require a minor expansion (260 square feet) of the facility compound fence line.

A copy of the full Petition is attached for your review. If you have any questions regarding this Petition, please contact me or the Siting Council directly at (860) 827-2935.

Sincerely,



Kenneth C. Baldwin

Attachment

33404513-v1

KENNETH C. BALDWIN

One State Street
Hartford, CT 06103
Main (860) 275-8200
Fax (860) 275-8299
kbaldwin@rc.com
Direct (860) 275-8345

Also admitted in Massachusetts

February 2, 2026

Via Certificate of Mailing

Dennis Goderre, Director Land Use and Development
Town of Montville
310 Norwich-New London Turnpike
Uncasville, CT 06382

Re: **Cellco Partnership d/b/a Verizon Wireless – Petition for Declaratory Ruling Filed with the Connecticut Siting Council for the Installation of a Wireless Telecommunications Facility at 401 Chapel Hill Road, Montville, Connecticut**

Dear Mr. Goderre:

This firm represents Cellco Partnership d/b/a Verizon Wireless (“Cellco”). Today, Cellco filed a Petition for Declaratory Ruling (“Petition”) with the Connecticut Siting Council (“Council”) seeking approval for the installation of a wireless telecommunications facility at 401 Chapel Hill Road in Montville (the “Property”).

The proposed Cellco facility will consist of the installation of nine (9) panel type antennas and six (6) remote radio heads at the 160-foot level on the existing 300-foot SubCarrier Communications tower. Equipment associated with the antennas and a diesel-fuel back up generator will be located on the ground near the base of the tower. Installation of the Cellco ground-base equipment and generator will require a minor expansion (260 square feet) of the facility compound fence line.

A copy of the full Petition is attached for your review. If you have any questions regarding this Petition, please contact me or the Siting Council directly at (860) 827-2935.

Sincerely,



Kenneth C. Baldwin

Attachment

33404619-v1

February 2, 2026

Via Certificate of Mailing

SubCarrier Communications, Inc.
139 White Oak Lane
Old Bridge, NJ 08857

Re: Cellco Partnership d/b/a Verizon Wireless – Petition for Declaratory Ruling Filed with the Connecticut Siting Council for the Installation of a Wireless Telecommunications Facility at 401 Chapel Hill Road, Montville, Connecticut

Dear Sir or Madam:

This firm represents Cellco Partnership d/b/a Verizon Wireless (“Cellco”). Today, Cellco filed a Petition for Declaratory Ruling (“Petition”) with the Connecticut Siting Council (“Council”) seeking approval for the installation of a wireless telecommunications facility at 401 Chapel Hill Road in Montville (the “Property”).

The proposed Cellco facility will consist of the installation of nine (9) panel type antennas and six (6) remote radio heads at the 160-foot level on the existing 300-foot SubCarrier Communications tower. Equipment associated with the antennas and a diesel-fuel back up generator will be located on the ground near the base of the tower. Installation of the Cellco ground-base equipment and generator will require a minor expansion (260 square feet) of the facility compound fence line.

A copy of the full Petition is attached for your review. If you have any questions regarding this Petition, please contact me or the Siting Council directly at (860) 827-2935.

Sincerely,



Kenneth C. Baldwin

Attachment

33404668-v1

ATTACHMENT 6

February 2, 2026

Via Certificate of Mailing

«Name_and_Address»

Re: Cellco Partnership d/b/a Verizon Wireless – Petition for Declaratory Ruling Filed with the Connecticut Siting Council for the Installation of a Wireless Telecommunications Facility at 401 Chapel Hill Road, Montville, Connecticut

Dear «Salutation»:

This firm represents Cellco Partnership d/b/a Verizon Wireless (“Cellco”). Today, Cellco filed a Petition for Declaratory Ruling (“Petition”) with the Connecticut Siting Council (“Council”) seeking approval for the installation of a wireless telecommunications facility at 401 Chapel Hill Road in Montville (the “Property”).

The proposed Cellco facility will consist of the installation of nine (9) panel type antennas and six (6) remote radio heads at the 160-foot level on the existing 300-foot SubCarrier Communications tower. Equipment associated with the antennas and a diesel-fuel back up generator will be located on the ground near the base of the tower. Installation of the Cellco ground-base equipment and generator will require a minor expansion (260 square feet) of the facility compound fence line.

This notice is being sent to you because you are identified on the Town Assessor’s records as an owner of land that abuts the Property. If you have any questions regarding the Petition, the Council’s process for reviewing the Petition or the details of the filing itself, please feel free to contact me at the number listed above. You may also contact the Council directly at 860-827-2935.

Sincerely,

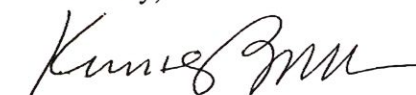

Kenneth C. Baldwin

Attachment

33404689-v1

CELLCO PARTNERSHIP D/B/A VERIZON WIRELESS

ABUTTING PROPERTY OWNERS

**401 CHAPEL HILL ROAD
MONTVILLE, CONNECTICUT**

	Property Address	Owner's and Mailing Address
1.	414 Chapel Hill Road	Connecticut Light and Power Company P.O. Box 270 Hartford, CT 06141-0270
2.	Chapel Hill Road	Joseph and Diane Bonner 774 Old Colchester Road Uncasville, CT 06382
3.	411 Chapel Hill Road	Chapel Hill Cemetery 411 Chapel Hill Road Oakdale, CT 06370
4.	377 Chapel Hill Road	Julius Meyer, III 377 Chapel Hill Road Oakdale, CT 06370

