

LEGEND

- These standard symbols may be found in the drawing.
- ★ Light Pole
 - CONC. Concrete
 - BIT. Bituminous
 - ∅ Utility Pole
 - WV Water Valve
 - GV Gas Valve
 - X - Chain Link Fence
 - Boundary Line
 - Edge of Road / Drive
 - Stone Wall
 - Catch Basin
 - CB Sewer Manhole
 - SMH 6" Iron Pipe Set
 - L.P.S. Railroad Spike Found
 - RR SPIKE FOUND Drill Hole Found
 - D.H.F. Drill Hole Set
 - WLF 2 Wetland Flag
 - GMS Granite Merestone
 - EX. CONC. MON. Existing Concrete Monument
 - T.S. To Be Set
 - CHD CT Highway Department Monument
 - Existing Contour Line
 - BCLC Bit Conc Lipped Curbing

Zoning Compliance Chart	
Zone: C-1 Parking	
Inventory Parking Stalls	Provided: 24 Spaces
Employee Parking	0
Customer Parking	0
Total Spaces:	24 Spaces

GENERAL NOTES:

- Reference is made to the following plans:
 - "Improvement Location Survey, Prepared for Joseph Wypianski, 904 Connecticut Route #32, Montville, Connecticut, Scale: 1"=20', Dated: November 7, 2013." Plan surveyed and mapped by Mark H. Sullivan. Plan provided by client.
 - "Property / Boundary Survey, Prepared for Joseph Wypianski, 904 Connecticut Route #32, Montville, Connecticut, Scale: 1"=20', Dated: December 27, 2011." Plan surveyed and mapped by Mark H. Sullivan. Plan provided by client.
 - "Plan of Houghton Park, Owned And Developed By Arthur G. Pattison, Montville, Connecticut, Dated: June 1911." Plan surveyed and mapped by Geo. E. Pitcher. Plan filed in the Montville Town Clerk's Office as Map Nos. 55 and 56.
 - "Connecticut State Highway Department, Right Of Way Map, Town Of Montville, Norwich - New London Road From Uncasville Switch Northerly About 6100 Feet, Route 12, Scale: 1"=40', Sheet Number 9012, Sheet 1 of 2, Dated: Feb. 27, 1931." Plan provided to Florek Surveying LLC by the Connecticut Highway Department.
- Not all underground utilities have been shown. Call before you dig (CBYD) is recommended prior to any construction.
- North orientation is based on two independent RTK GNSS observations utilizing the Acom Network in May 2025.
- The word certify as used is understood to be an expression of professional opinion by the surveyor. It is a declaratory statement which is based on the surveyor's best knowledge, information and belief. As such it constitutes neither a guarantee nor warranty, expressed or implied, of any information contained hereon.
- Removal or destruction of survey monumentation, whether set or found, as shown on this survey plan may be subject to Connecticut Statute 47-34a.
- Reference is made to Montville Town Clerk Volume 679 Page 534 for the subject property.
- Subject property has the right to install and maintain a drainage easement onto 882 Rte 32. Reference Volume 630 Page 486.

SURVEY NOTES:

- This survey has been prepared in accordance with "The Standards and Suggested Methods and Procedures for Surveys and Maps in the State of Connecticut" Prepared and Adopted by the Connecticut Association of Land Surveyors, Inc. on August 29, 2019. This survey type is a PROPERTY SURVEY based on a RESURVEY OF map reference 1 a - d. It is intended to show A PROPOSED ACCESSORY PARKING AREA.
- This survey conforms to Class A-2 / T-2 / V-3

To the best of my knowledge and belief this map is substantially correct as noted thereon.

Brian D. Florek LS CFS 05-17-2025

Brian D. Florek, LS, CFS #70135 / NCFS-026 Date:
 Managing Member, Florek Surveying, LLC
 239 Shore Road, Waterford, CT 06385
 bflorek@floreksurveyingllc.com (860) 271.6006

Not Valid Without Embossed Seal

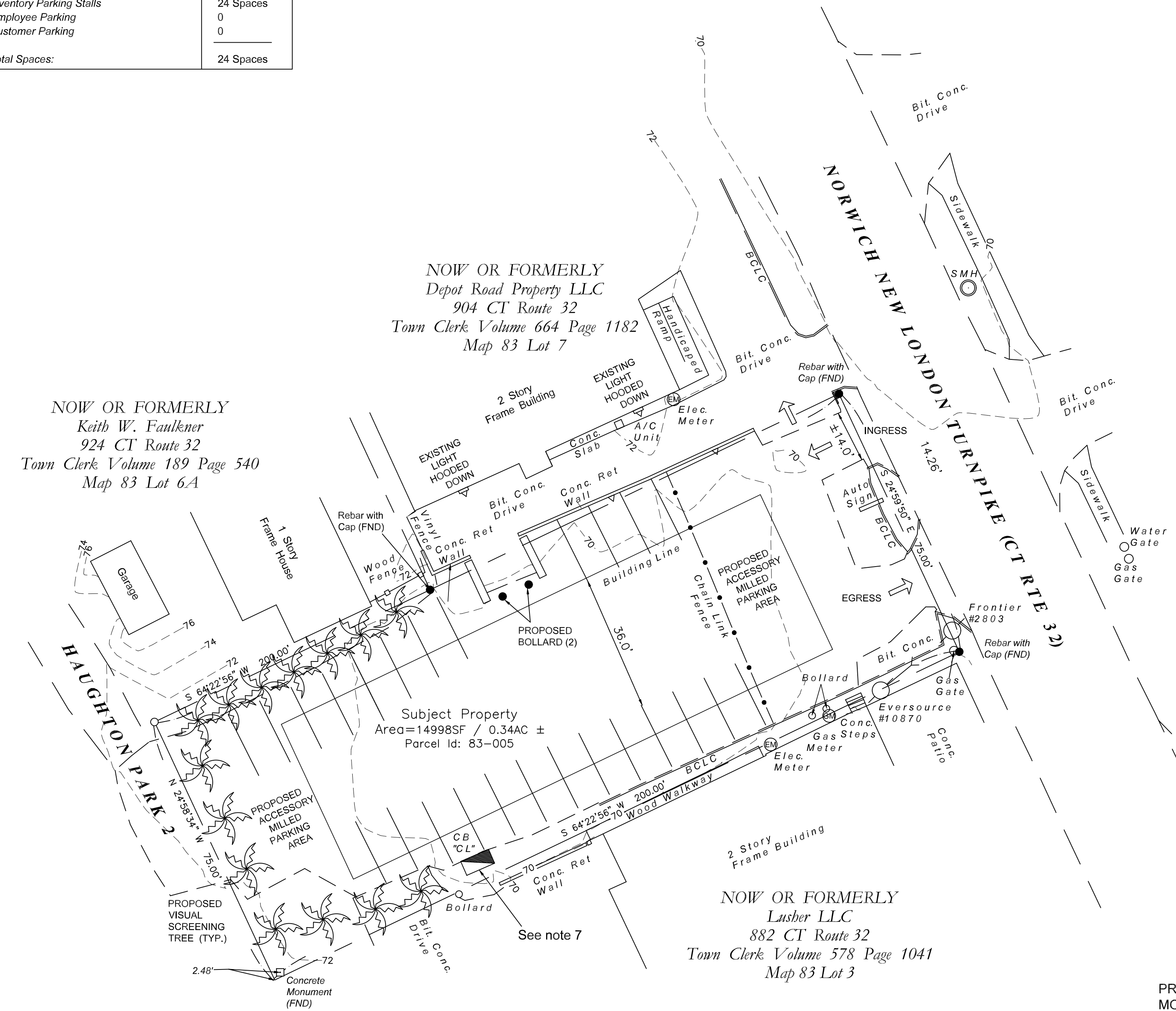
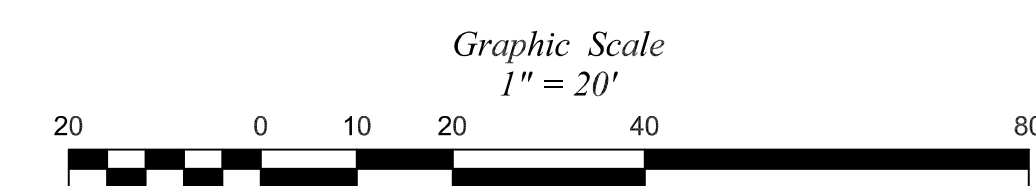

PARKING LOT NOTES:

- The subject parcel is proposed as an accessory parking area to the adjoining commercial use located at 904 CT Rte. 32.
- There will be no employee parking.
- There will be no customer parking.
- There will be no storage of wreckers or flatbeds associated with this business.
- Existing lighting to be placed on 924 Route 32 Building. All exterior lighting associated with the proposed parking area shall be mounted on the existing building and shall consist of fully shielded, hooded, downcast fixtures designed to prevent glare and light trespass onto adjacent properties and streets.
- Proposed parking area to remain recycled stone.
- One way traffic in through north drive.
- The subject parcel and adjoining commercial parcel are under common ownership. No cross-access easement is required at this time. In the event of separate conveyance, appropriate cross-access easements shall be established.
- No additional buildings or site development are proposed as part of this application.
- Proposed visual screening evergreens to be plated along the northwestern and western property lines as shown to provide screening to residential use.
- No night use of parking lot.
- Use = Storage of cars.

PROPOSED LIGHT FIXTURE (TO BE MOUNTED ON EXISTING BUILDING)

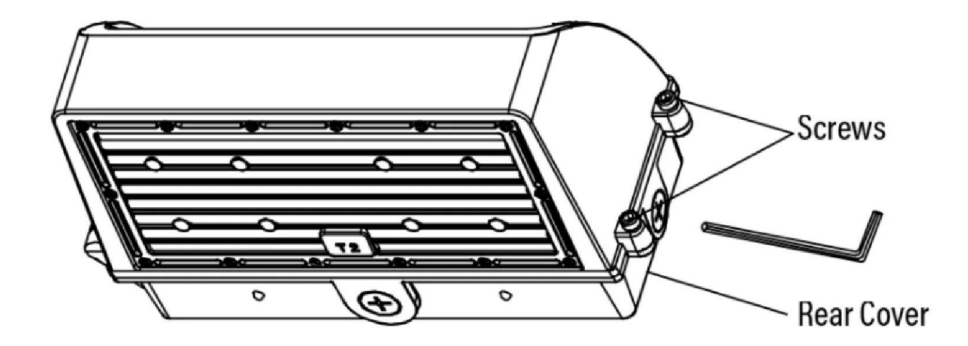
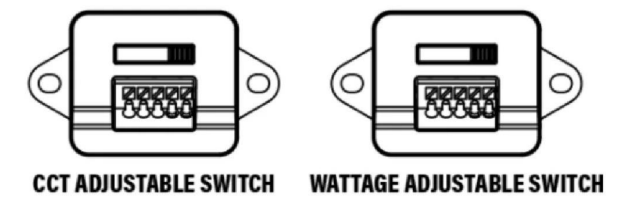
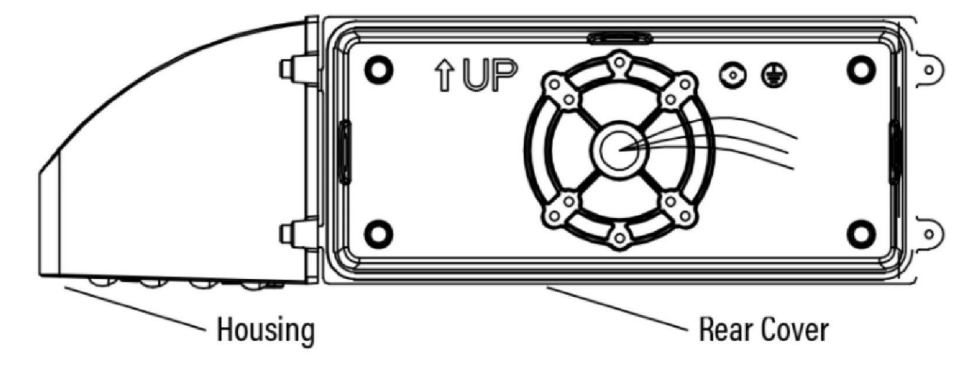

Florek Surveying, LLC

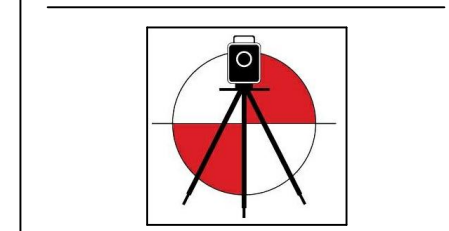

239 Shore Road
 Waterford, CT 06385
 (860) 271.6006
 bflorek@floreksurveyingllc.com

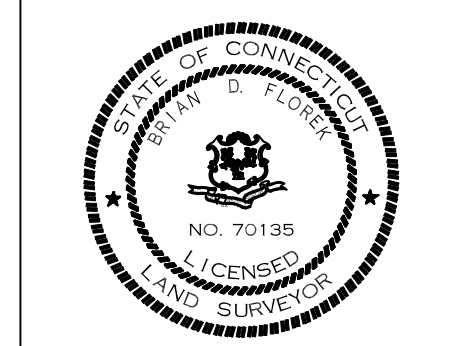

REVISION TABLE		BY	BF
DATE	REVISION		
3-10-26	Lighting & Parking Lot		
4-3-26	Town Comments		

PROPERTY SURVEY
 PREPARED FOR:
 DEPOT ROAD PROPERTY LLC
 888 CT ROUTE 32
 MONTVILLE, CONNECTICUT

SHEET No.:	1
OF 1	
SCALE:	1" = 20'
DATE:	May 17, 2025
PROJECT No.:	25-20
FILE:	25-20_086_888-Rte32_Pennell-20scale
TITLE NAME:	25-20_086_888-Rte32_Pennell-20scale.dwg
SURVEYED BY:	TN
DRAWN BY:	AM/BF